

# Gaylord

Your Trusted Source®

## GUIDE TO COLLECTIONS CARE

*Paper, Photographs, Textiles & Books*



**PLUS**, check out our Resource Section for more information on preservation and conservation.

SEE PAGES 56-60.

CALL: 1-800-448-6160

FAX: 1-800-272-3412

WEB: GAYLORD.COM

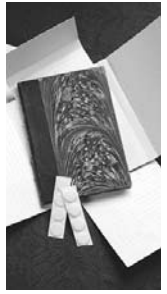

# Gaylord

Your Trusted Source™

## A CONTINUUM OF CARE

Gaylord's commitment to libraries and the care of their collections dates back more than eighty years. In 1924, the company published *Bookcraft*, its first training manual for the repair of books in school and public libraries. Updated regularly, the publication has provided librarians with simple cost-effective techniques for the care of their collections.

When the field of preservation expanded during the 1980s, Gaylord responded with a line of archival products. In 1992, it issued its first Archival Supplies Catalog, followed by its innovative series of *Pathfinders*. Written by conservators, these illustrated guides earned a reputation for reliable information on the care and storage of paper, photographs, textiles, and books.

This *Guide to Collections Care* continues Gaylord's commitment to providing its users with the reliable information they need to preserve their treasures. Conservators have updated the information from our original *Pathfinders* and combined all five booklets into this one easy guide. We have also added product references as a convenient resource tool.

©2010, Gaylord Bros., Inc.  
All rights reserved.  
Printed in USA

Gaylord Bros.  
PO Box 4901  
Syracuse, NY 13221-4901

Gaylord Bros. gratefully acknowledges the authors of this pamphlet:

Nancy Carlson Schrock  
Deborah Bede  
Tania Passafiume  
Beth Patkus

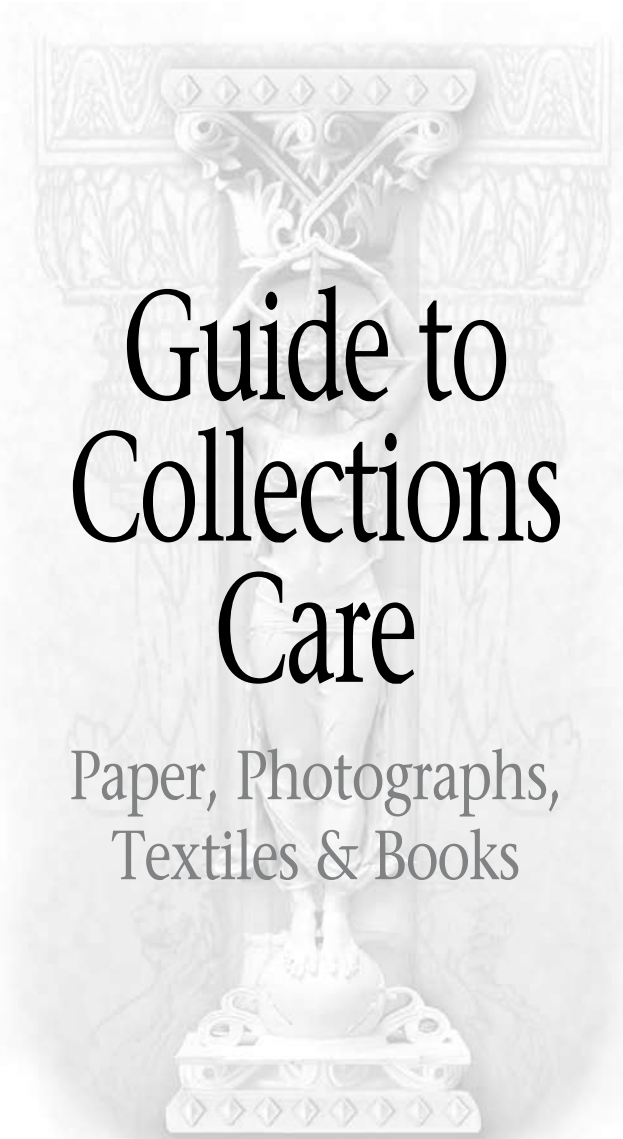

# Guide to Collections Care

Paper, Photographs,  
Textiles & Books

## ORDERING

To Order call:

8:00 am–7:00 pm EST Monday–Friday

**1-800-448-6160**

FAX Anytime

**1-800-272-3412**

Order online

**Gaylord.com**

## CUSTOMER SERVICE

Call:

8:00 am–7:00 pm EST Monday–Thursday &

8:00 am–6:00 pm EST Friday

**1-800-634-6307**

FAX Anytime

**1-800-272-3412**

---

# Table of Contents

---

## **Archival Storage of Paper**

---

SECTION 1 **2**

## **Archival Storage of Photographs**

---

SECTION 2 **18**

## **Archival Storage of Textiles**

---

SECTION 3 **36**

## **Introduction to Book Repair**

---

SECTION 4 **46**

## **Resources**

---

SECTION 5 **56**

## 1

## SECTION

# Archival Storage of Paper

<b>Introduction</b>	<b>2</b>
<b>Selecting Storage Materials</b>	<b>3</b>
Terminology	<b>3</b>
Types of Enclosures	<b>4</b>
<b>Standards for Materials</b>	<b>5</b>
<b>Preparing Collections</b>	<b>6</b>
<b>Selecting Storage Furniture</b>	<b>6</b>
<b>The Storage Environment</b>	<b>7</b>
<b>Case Studies</b>	<b>8</b>
I: Documents	<b>8</b>
II: Oversized Documents	<b>11</b>
III: Works of Art	<b>12</b>
IV: Pamphlets	<b>13</b>
V: Periodicals & Newspapers	<b>14</b>
VI: Ephemera	<b>15</b>
VII: Books & Other Bound Materials	<b>16</b>

## Introduction

Documents, manuscripts, prints, drawings, pamphlets, periodicals, newspapers, postcards and ephemera are typically made of paper—an organic substance that is vulnerable to deterioration over time.

All paper will deteriorate if mistreated or stored improperly. Some types of paper are particularly vulnerable—for example, the acidic wood-pulp paper that was produced throughout much of the 19th and 20th centuries. Unlike earlier papers, which were made of higher-quality fibers (commonly called rag papers), wood-pulp papers contain natural impurities and byproducts of the manufacturing process that break down to form acids in the presence of heat, light, and moisture in the air. Pollutants in the air and/or direct contact with poor-quality storage enclosures also cause discoloration and embrittlement of paper.

There are a number of steps that can be taken to preserve vulnerable paper collections. These include providing a cool, dry, clean, dark, and stable environment; protecting collections from disaster; handling collections carefully; choosing appropriate storage furniture; and using protective storage enclosures. Storage enclosures lessen the effects of fluctuations in temperature and humidity and provide protection against abrasion and handling, but they must be strong, durable, and chemically stable so that they do not damage the materials they enclose.

The goal of this section is to provide the background information necessary to select the most appropriate storage systems for flat paper (storage of photographs is addressed in a later section of this publication). It is oriented toward collectors, artists, archivists, and librarians who are new to the field of preservation. No introduction, however, can provide all the answers. For further information, consult the readings in Section 5. If your collections are extensive, in poor condition, or include works of art, it would be advisable to consult a professional conservator. The American Institute for Conservation of Historic and Artistic Works (AIC) provides an online guide, “Find a Conservator” (at [www.conservator-us.org](http://www.conservator-us.org)) that provides the names of conservators in your region. If you are unable to use the online guide, contact AIC at 202-452-9545 or email [info@aic-faic.org](mailto:info@aic-faic.org).

The information in this section reflects our current understanding of the storage requirements for paper. It will be revised as new information and products become available. Unless noted otherwise, all of the items illustrated in this section are available from Gaylord. Call 1-800-448-6160 for a free Catalog or visit us online at [Gaylord.com](http://Gaylord.com).

## Selecting Storage Materials

To provide long-term protection, storage containers and enclosures should be made of materials that are strong, durable, and chemically stable. Enclosures and boxes should be tailored to the size, condition, and anticipated use of the objects being enclosed.

### TERMINOLOGY

The terms “archival” and “archival quality” are often used to describe storage products, but these are non-technical terms that do not, of themselves, convey any specifics about the suitability of these products for use in preservation. It is important to evaluate the specific characteristics of each product and to choose the appropriate type of product for the item to be stored. For storage materials made from paper and/or board, these characteristics include (but are not limited to) acidity, alkalinity, the presence of lignin, fiber type, and adhesives used. Note that different characteristics apply to plastic storage materials, which will be considered separately below.

Acidity and alkalinity are measured by pH using a logarithmic scale of 0–14. The pH of storage materials made from paper and board should ideally be in the 7–8.5 range.

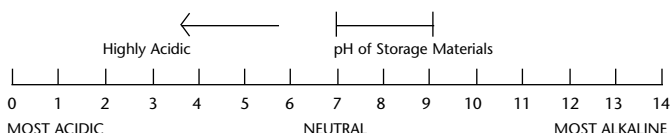

Paper to be used for storage enclosures should be **acid-free**. Acid-free storage materials have a pH of 7.0 or higher. It is important to realize that although acid-free materials are not acidic when they are produced, they can become acidic over time. This can be due to internal impurities introduced in manufacturing or to external impurities such as pollutants, which degrade to produce acids.

For this reason, an **alkaline reserve or buffer** is often added to paper or board during manufacture to neutralize acids that may be produced over time. This alkaline reserve is usually 2-3% calcium or magnesium carbonate. Most paper collections will require buffered enclosures. While an alkaline buffer in storage enclosures is generally desirable, *there are a few types of collections that are sensitive to alkaline materials and should therefore be stored in pH-neutral enclosures, not alkaline*. These include blueprints and diazo reproductions, works of art with pigments that react to high pH, and albums and collages with wool or silk components. Some photographs and textiles may also be alkaline-sensitive; see later sections of this publication for more information on these materials.

Storage materials for paper objects should also be **lignin-free**. Lignin is a natural component of the cell walls of plants and trees. If it is not removed during manufacture, it can react with light and heat to produce acids and darken paper. Lignin-free actually means low-lignin; lignin-free materials usually have a maximum of 1% lignin.

Other components of paper or board enclosures that should be considered when determining their suitability for long-term preservation include fiber type and adhesives used in the enclosures. While cotton fiber makes the most chemically stable paper and board, it is possible to make high quality paper and board from wood pulp by using a chemical process that

**Please Note:** Product number references in text and photos along outside column all represent Gaylord product groups. Additional sizes, colors, etc. may be available. Please go to [Gaylord.com](http://Gaylord.com) and use product number or keyword description to find full selection.



Flip-Top  
Document Cases



Clamshell  
Archive Boxes



Acid-Free Folders



Mat Board

removes impurities (the resulting pulp is usually termed **chemical wood pulp** or **purified wood pulp**). **Groundwood pulp** (also known as **mechanical wood pulp**), on the other hand, is always of poor quality and cannot be used to make suitable enclosures. In addition, adhesives used in enclosures must not discolor, deteriorate, or fail, and they should not discolor or damage adjacent materials.

The *American National Standard for Permanence of Paper for Publications and Documents in Libraries and Archives* (referenced on page 58) provides specifications for paper that will last several hundred years under normal use. This standard is intended for publishers and paper manufacturers, but can also be useful in evaluating paper enclosures. For more information on evaluating storage materials, see the *ANSI/NISO Guidelines for Information About Preservation Products* (referenced on page 57). While this publication does not set standards for products, it does provide guidelines for the types of information vendors include in their catalogs, and it provides a useful glossary of terms.

## TYPES OF ENCLOSURES

**Boxes:** The boxboard used for most document boxes is 60mils or points (pts.) thick (there are 1000 points in an inch, so 60 pts. is .060 inches thick). Lighter weight stock (40 pt.) is sometimes used for small boxes. Boxes suitable for long-term storage of paper items are available in several types of board—blue/gray with a white liner (D12102), unlined tan (D12102LF), or unlined black (DB12102)—all of which are acid-free, lignin-free, and buffered, with a pH of 8.0-9.0. Boxes are also available with a polyester film laminate coating (ACD12102) to resist water damage. All boxes should be sturdy enough to support the contents and have reinforced corners and snug covers that prevent soil and pollutants from entering.

**Folder Stock:** Acid-free folders (RF9115) of various sizes are available in both buffered and non-buffered stock. The typical weight is 10-pt. with 7-pt. available for lightweight items and 20-pt. for oversized maps and prints.

**Interleaving Material:** Interleaving sheets are sometimes used to protect paper objects in storage. Tissue, glassine, various types of paper, and clear polyester film can be used for this purpose. Acid-free tissue (BT30405) is available with or without an alkaline buffer, as is paper (PB811). Glassine (UG810) is a smooth translucent paper that is not abrasive and can generally be used with friable media such as pastel or charcoal, but it is not very stable. Glassine is acid-free and unbuffered, and should be replaced periodically if used. If polyester film (410122) is used for interleaving, it should meet the criteria for safety noted below, and it should not be used for items with friable media because of its electrostatic charge.

**Mat Board:** When matting and framing works of art on paper, conservation mounting/matting board (either a 100% cotton rag board or a purified wood pulp board) must be used both for the backboard and the window mat. For most materials, mat board (RBW21114/RCMBW21114) should be acid-free, alkaline buffered, and lignin-free—with the exception of the alkaline-sensitive materials mentioned on page three. For these materials, an unbuffered 100% cotton rag board (RNBW41114) is available. Mat board is available in two- and four-ply thickness. The heavier weight is recommended for oversized documents that need additional support. For hinges used to attach works of art to the backboard, Japanese paper (JTPSN/JTPSW) (which is lightweight, lignin-free, and long-fibered) and a starch-based paste (52000) are recommended.

**Plastic:** Clear plastic enclosures are particularly useful for objects that receive continual handling, are too brittle to be handled unprotected, or like postcards, must be browsed to view the images. As noted above,

artwork with friable media such as charcoal or pastel should never be placed in plastic because static electricity can lift the image from its support. Remember that plastic enclosures provide no protection from light. All items in clear plastic enclosures should be placed in boxes for long-term storage.

Polyester, polypropylene, and polyethylene are the three types of plastic that are suitable for storage of paper objects. They should be uncoated and free of additives. Uncoated polyester, sold under the brand Melinex®, is recommended because it is very stable. It is used for various types of envelopes (M453), sleeves (MP45), and folders (6255AL). Polyester also comes in rolls (MR1200) or pre-cut sheets (410122) and is available in thicknesses of 1 to 5mil; 2 to 3mil is used for average-sized documents, while oversized prints and maps need the extra support of 4 to 5mil. Polypropylene is commonly used for containers (62013). Polyethylene is highly flexible but not as clear; it is used for sleeves (PB35/2810) and bags (Z223). Polyvinyl chloride (PVC) enclosures, sometimes referred to as vinyl, are not acceptable for use, because they are very unstable.

Documents may also be encapsulated between sheets of polyester using double-sided tape [3M No. 415 (6265A)] with a  $\frac{1}{4}$ " margin between the document and the tape. However, current research indicates that acidic paper deteriorates more rapidly if sealed in polyester. It is advisable to place sheets of buffered paper (PB811) behind the documents before putting them in polyester, or to consult a conservator about having them deacidified. An alternative to encapsulation, especially suitable for oversized documents, is a folder with a polyester cover sheet (F10125).



Envelopes—  
3mil Melinex



L-Sleeves—  
3mil Melinex



Document Folders—  
2mil Melinex

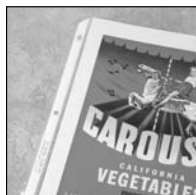

Sheet Protectors—  
Polypropylene

## Standards for Materials

While there is no one standard that specifically governs storage materials for paper objects, there are several standards that provide helpful information for evaluating individual products. These include the *American National Standard for Permanence of Paper for Publications and Documents in Libraries and Archives*, ANSI/NISO Z39.48-1992(R2002); *Guidelines for Information About Preservation Products*, ANSI/NISO Z39.77-2001; and *Photography—Processed Photographic Materials—Photographic Activity Test for Enclosure Materials*, ISO 14523:1999. The Photographic Activity Test (PAT) is a standardized test that is used to determine whether enclosure materials are safe to use with silver image photographs. It is discussed further in the section on storage of photographs.

Responsibility for adherence to standards rests with the suppliers. Gaylord Archival Products are manufactured to the most recent national preservation standards. The company purchases or manufactures materials to standards published by the American National Standards Institute (ANSI), the National Information Standards Institute (NISO), and the International Organization for Standardization (ISO) when available, or industry-wide standards established by national institutions such as the National Archives and Records Administration and the Library of Congress Preservation Directorate. Specification information is available from Gaylord on request.

**Please Note:** Product number references in text and photos along outside column all represent Gaylord product groups. Additional sizes, colors, etc. may be available. Please go to [Gaylord.com](http://Gaylord.com) and use product number or keyword description to find full selection.



White Cotton Gloves



Archival Bond Paper



Newspaper Sleeves



Foil-Back Labels

## Preparing Collections

Once you have selected the appropriate storage materials, the documents and other paper items should be prepared for storage. Always follow proper handling procedures when working with collections. Using white cotton gloves (71200) will protect items from dirt and oils on your hands. Do not eat or drink around collections. When moving paper documents or artworks, particularly brittle items, support the item carefully from below.

1. **Remove extraneous materials**—paper clips, rubber bands, wrapping material, old folders, and any other material that is not pertinent. If foreign matter (such as pressed flowers) must be saved as artifactual evidence, place it in a separate enclosure.
2. **Unfold and flatten papers wherever possible without causing damage to the folds.** Remove letters from envelopes. If the paper is brittle or inflexible, it may need to be humidified before unfolding. Consult a conservator for proper procedures. Prints, drawings and extremely fragile or valuable items should be treated by a conservator. Once materials have been unfolded, remove surface soil with a soft brush (59069).
3. **Isolate newsprint because it is highly acidic and will stain adjacent paper.** Newspaper clippings can be replaced with photocopies on alkaline paper (PB811) or placed into a separate envelope. Fax copies are similarly unstable and should be reproduced or isolated.
4. **Note any badly damaged items**—place them in individual folders, and set them aside for professional conservation treatment. Do not undertake any “first aid” unless you have received training and are qualified to do so.
5. **If it is necessary to place identifying information on the object itself, use a No. 2 pencil** and write on the verso or in the lower right margin. Repeat the identification on storage folders and envelopes in pencil or by applying typewritten labels. Never use ball-point or felt-tip pens that might stain or bleed. Never apply labels directly to a document or work of art; labels are intended for boxes, folders and other enclosures.
6. **To the extent possible, store objects of similar size and weight together.** If heavy or bulky items are stored with lighter ones, damage can occur from uneven pressure.
7. **Label boxes with adequate information about their contents.** This curtails unnecessary browsing and rifling through the documents.

## Selecting Storage Furniture

Once paper objects have been placed in enclosures and boxes, they must be stored in non-damaging furniture. Wood storage furniture is not recommended because it can emit acids and other harmful substances. It is possible to use a sealant on wood furniture, but this will not provide complete protection, and the sealant itself may emit damaging vapors. Even if wood shelves and drawers have been sealed, they must be lined with a barrier material such as Marvelseal® (M3610/M4750) for additional protection. See “Storage Furniture: A Brief Review of Current Options” in the NEDCC publication referenced on page 57 for more information.



Metal furniture with a baked enamel coating is acceptable for preservation purposes, but powder-coated steel or anodized aluminum furniture is preferred. As with enclosures, the choice of furniture will depend on the budget and the types of materials in the collection.

Regardless of the type of furniture, it should be appropriate for the types of collections to be stored in it. Open shelving is best for air circulation, although closed cabinets are sometimes needed for security purposes. Shelves should be adjustable, and collections should not protrude off the shelves or be crowded together. The lowest shelf should be 4-6 inches off the floor to reduce the chance of damage from flooding. Specialized furniture that will allow oversized items to be stored flat [e.g., map cases (4994-01) or shelving for oversized boxes (RAS42153/5285-01)] should be used.

## The Storage Environment

A cool, dry, and stable storage environment is crucial to the long-term preservation of paper collections. Heat and moisture accelerate the chemical reactions that cause paper to deteriorate, and high moisture levels can result in mold growth. Research has shown that lower temperatures and a lower relative humidity will greatly extend the usable life of paper collections.

Maintaining a stable environment is also very important. While boxes and storage enclosures can provide some protection against short-term environmental fluctuations, they will not protect collections against long-term changes in environmental conditions. Over time, climate fluctuations can cause paper to expand and contract, leading to distortion and weakening of the paper. Research has shown that large and frequent fluctuations—such as those that occur at night and on weekends if climate control systems are turned off or settings are altered—greatly accelerate paper deterioration.

There is no national standard for environmental conditions, but the National Information Standards Organization (NISO) has issued a technical report entitled *Environmental Guidelines for the Storage of Paper Records* (referenced on page 58), which gives suggested values for temperature and relative humidity for storage of paper records in libraries and archives. This report recommends a temperature no higher than 70°F and a relative humidity somewhere between 30% and 50% that can be maintained consistently.

Some practical suggestions for keeping the environment moderate and stable include: using portable dehumidifiers and air conditioning units in summer to lower humidity; lowering heat levels in winter to prevent humidity from becoming extremely low; and avoiding storage of collections in basements or attics where climate extremes tend to occur.

It is a good idea to monitor the climate in storage areas to ensure that it remains moderate and stable. Monitoring instruments ranging from humidity indicator cards (62031) to hygrothermographs (373Q) and dataloggers (59029) are available. See the NEDCC publication (referenced on page 57) for more information on choosing an appropriate monitor and implementing an environmental monitoring program.



Shelving



Map Cases



Humidity Indicator Cards



Hygrothermographs



Dataloggers

**Please Note:** Product number references in text and photos along outside column all represent Gaylord product groups. Additional sizes, colors, etc. may be available. Please go to [Gaylord.com](http://Gaylord.com) and use product number or keyword description to find full selection.



Envelope Slings



Melinex® Envelopes



20 lb. Buffered Paper

## Case Studies

Selecting specific enclosures and boxes requires careful consideration. Physical condition, size of collection, anticipated use, and budget all play a part in the final choice. The second half of this section will present several case studies to show how products available from Gaylord can be used to solve the storage needs of paper collections.

### CASE STUDY 1: DOCUMENTS

**Scope:** Documents, Manuscripts and Papers (letter or legal size)

**A. Select appropriate primary enclosures that will protect the contents and allow them to be removed for use without damage.** The size should be larger than the unfolded sheets so that edges don't protrude and become damaged.

1. *Papers that are strong, flexible, and of similar size can be placed directly into acid-free folders.* The number of items per folder depends upon the thickness of the paper, the condition of the paper, and the nature of the document. For example, a single folder can be used to house one valuable print, 10–15 older manuscripts, or 50 modern office records. Providing adequate protection is the primary concern. Folders come with and without reinforced tabs, in letter or legal sizes with full, half, third or fifth cut tabs. (ARF120/RF9115/F9115)
2. *Papers that are acidic, fragile, brittle, or torn need additional support and protection before placing them in folders.* Options for protection include:
  - (a) Paper folders (911A) or Slings (ES58A). Insert the item into a paper folder or envelope sling before placing it into a folder. Paper folders can also be used to group papers instead of using staples or paper clips, which can be damaging.

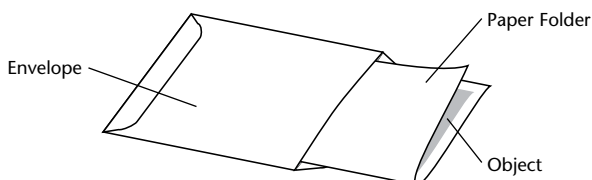

- (b) Individual polyester enclosures (M453). These provide fragile or small items with protection from handling while retaining visibility.
- (c) Interleaving with 20 lb. buffered paper (PB811). This protects documents from adjacent material and provides support during handling, especially for oversized documents. Objects can be removed from folders by lifting the larger interleaving sheets beneath them.

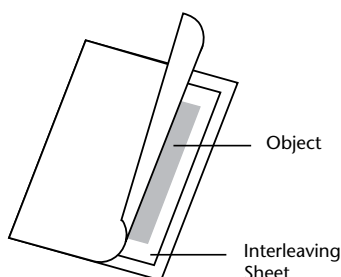

Use interleaving paper, envelopes, or folders to separate valuable documents from highly acidic materials such as newsprint or replace newspaper clippings with photocopies on alkaline paper.

3. *Paper envelopes can also be used to organize collections.* Short (FF69) or long (E911) side opening envelopes can house groups of papers or thin pamphlets on sturdy paper. Envelopes must be large enough for items to be easily inserted and removed without abrading the edges. If fragile papers or pamphlets are to be stored in an envelope, they must first be placed in a paper folder or envelope sling.

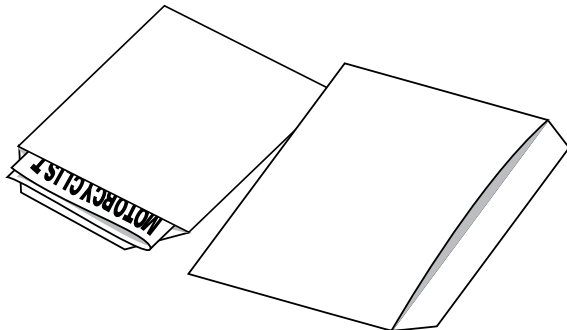

Fragile papers or pamphlets need the added protection of a paper folder or sling before being inserted into an envelope or folder.

Be aware that envelopes containing paper collections should not be interfiled with book collections, because envelopes do not provide sufficient support for the items stored inside. If pamphlets or groups of documents must be shelved with books rather than in boxes, the items should be placed in pamphlet binders (see Case Study IV, page 13).

4. *Groups of items can be placed into larger enclosures,* depending on the size of the collection, where it will be stored, and how it will be used. Expanding folders (E1210) are good for interim storage of collections that are growing rapidly, such as children's artwork, or active correspondence.

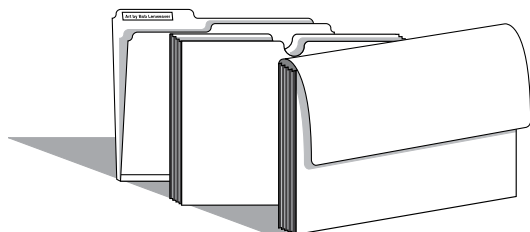

**B. Place folders and envelopes in sturdy boxes.** Storage boxes should be strong, have reinforced corners, and match the size of the enclosures. To the extent possible, store items of similar size and weight together. Heavy or bulky items can damage lighter items stored in the same box.



Paper Envelopes  
& Envelope Slings



Expanding Folders

**Please Note:** Product number references in text and photos along outside column all represent Gaylord product groups. Additional sizes, colors, etc. may be available. Please go to [Gaylord.com](http://Gaylord.com) and use product number or keyword description to find full selection.



Document Cases



Box Dividers

Drop-Front  
Storage Boxes

Hanging Folders

Record  
Storage CartonsHalf-Size Record  
Storage Cartons

1. *Upright storage in document cases (D12102) is generally recommended for archival collections.* All folders in a box should be the same size, and they should fit the size of the box. Folders must be adequately supported so that documents don't sag and become distorted.

Folders should fill the box comfortably so that individual folders can be easily removed.

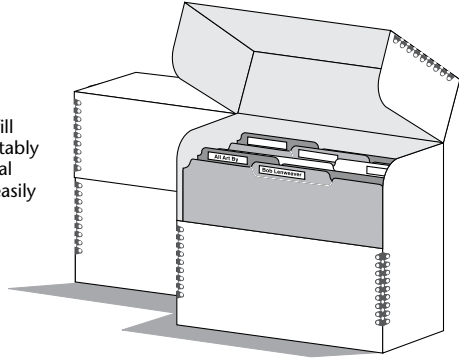

If there are not enough folders to fill a box, use an adjustable spacer (EFCB821) to hold the folders upright and prevent them from slipping or sagging.

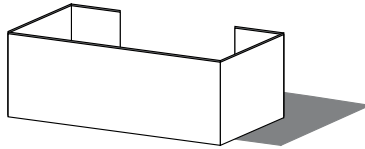

Adjustable document spacers can be purchased and fitted to your boxes. Dividers (EFDIVLTR) are also available to support and organize folders.

2. *Flat storage in drop-front storage boxes (PB1083) is sometimes appropriate, but also has some disadvantages.* It gives overall support, prevents damage from slumping, and protects edges of brittle documents—but documents on the bottom of the box can be distorted by pressure from the items above, particularly if items in the box are different sizes and weights. If flat boxes are used, they should have drop-front construction to make safe removal of folders easier. They should be stacked no more than two high.

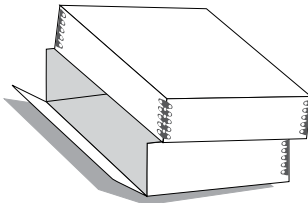

Drop-front Storage Box

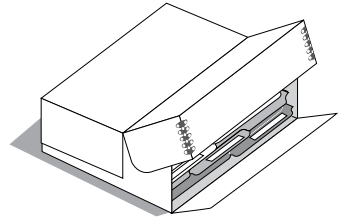

Drop-front Box with hinged lid

3. *Another acceptable storage alternative for paper documents is storage in a file cabinet with hanging folders.* Acid- and lignin-free buffered hanging folders (HF9111-25) are available. Depending on how many items are in each folder, one or more folders may be placed in each hanging folder.

**C. Large collections of office records should be stored in record storage cartons.** These are available in buffered (RC121510/U1215) and unbuffered (TC1215) board. The unbuffered cartons should be used only for short-term storage. Cartons must be strong and easy to transport.

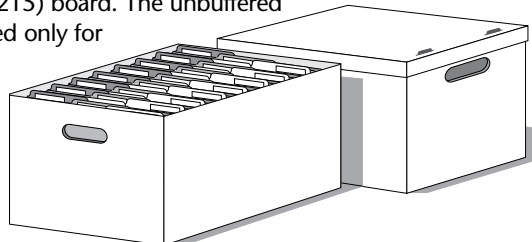

## CASE STUDY II: OVERSIZED DOCUMENTS

**Scope:** Documents, Papers, Maps, Posters and Ephemera (larger than legal size)

### A. Select primary enclosures that provide adequate support.

Folders (M1824/M3040) are available in large sizes and should be made of heavier 10- or 20-pt. folder stock (instead of 7- or 10-pt.). Likewise, 4mil polyester film (NP1117) or a combination of 2–3mil for the front sheet and 5mil for the back sheet should be used if oversized documents must be encapsulated.

Sheets should be sorted and grouped by size, if possible. Place no more than 10–12 sheets into a folder. See page four for advice about interleaving, which is recommended to support fragile oversized items. Remember that certain types of oversized documents (e.g., blueprints and diazo reproductions) will need acid-free (RFW9115) rather than buffered folders because of their sensitivity to alkalinity. If you buy both types of folders, be sure they are clearly labeled and staff knows when to use each type.

Storage/display folders with polyester cover sheets (F10125) allow the contents to be viewed without damage and provide a backing of buffered material. These are more expensive, but worth the investment if the oversized items are fragile, valuable, or handled frequently. Remember, however, that these should not be used for artwork with friable media that may be lifted off the support by the plastic.

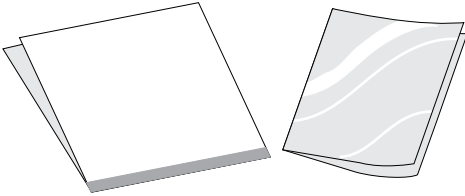

Large Format Folders



Poster Envelope & Backer Boards



Newspaper Sleeves



Curator Newspaper Boxes



Ackley Filing System

**B. For small collections, folders may be stored flat in drop-front storage boxes (DFBG1813).** Because of their weight, boxes should be stored no more than two high. Another option is the Ackley Filing System (EAAB) which consists of corrugated boxes, file folders, L-sleeves and box labels, and is designed for horizontal or vertical storage of large documents.

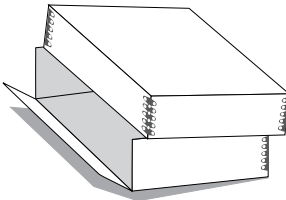

Drop-front Storage Box

### C. Large collections of oversized maps, posters, and architectural drawings are best stored inside folders in metal flat files (4994-01/7867-01).

Shallow drawers 1½ inches deep are preferable so that the folders on the bottom are not crushed. See page 6 for general information about storage furniture. As with storage in boxes, folders should be sized to fit the drawer, and all folders should be the same size.

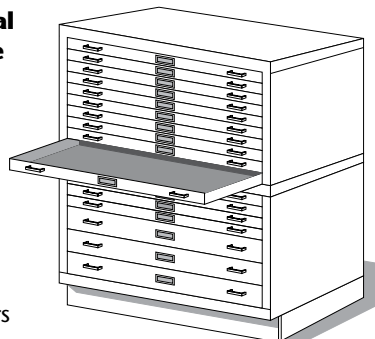

**Please Note:** Product number references in text and photos along outside column all represent Gaylord product groups. Additional sizes, colors, etc. may be available. Please go to [Gaylord.com](http://Gaylord.com) and use product number or keyword description to find full selection.



Roll Storage Tubes



Roll Storage Boxes



Clamshell Storage Boxes



Drop-Front Storage Boxes



Window Mats



Clamshell Portfolio Boxes

**D. Use rolled storage when items are too large for flat files, as long as the items are flexible enough to withstand rolling and unrolling.** Although flat storage is always preferable, it is not always possible. Rolled storage is a better alternative than sectioning maps or creasing drawings.

Use an acid-free tube (3638/52232) that has a diameter of 3" or more and is several inches longer than the largest item being rolled. Depending upon their size and condition, 1–6 items can be wrapped around the outside of a tube with interleaving (BT30405) between individual items. The image should face the inside so that it is not exposed to light. The rolled document should be wrapped on the outside with acid-free paper (BLP2450) or polyester (MJTS) wider than the document and secured with flat unbleached cotton tying tape (min.  $\frac{5}{16}$ " wide) (CT100). If the item is a blueprint, the wrapping paper or tissue should be unbuffered (UT30405). A roll storage box (R4430) will provide added protection.

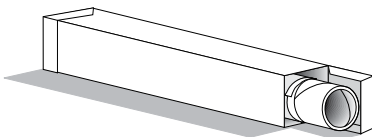
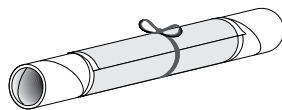
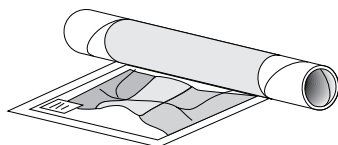

### CASE STUDY III: WORKS OF ART

The storage of prints and drawings is outside the scope of this pamphlet. If your collection includes such work, your storage needs should be reviewed by a conservator. In the interim, separate the items and follow these guidelines.

**A. Store artwork flat.** If possible, place each item in its own folder or place interleaving paper between each work of art to protect the surface. Remember that artwork with friable media such as charcoal or pastel should never be placed in plastic because static electricity can lift the image from its support. Place folders in clamshell (CL12103) or drop-front (PB1083) storage boxes.

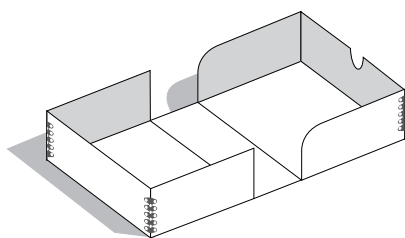

**B. For long-term storage of prints and drawings, conservators recommend window mats (PCM45-1A).** These should be stored flat in reinforced boxes. For a description of procedures, see the AIC brochure and *Matting and Framing for Art and Artifacts on Paper and How to Do Your Own Matting and Hinging* in the NEDCC publication (all are referenced on pages 57–58).

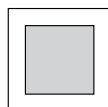
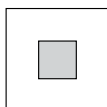

Although the size of the individual works of art may vary, they are often mounted in mats of consistent size and stored in flat storage boxes just large enough to accommodate the mats comfortably and eliminate any movement or shifting.

- C. Matted artwork requires sturdy boxes that can support the extra weight of the mats.** Their inner depth should be only 1 1/2 or 2 inches, again to keep the weight manageable.

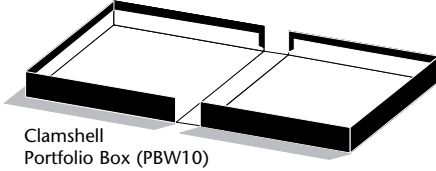

Clamshell  
Portfolio Box (PBW10)

## CASE STUDY IV: PAMPHLETS

**Scope:** Single Signature Pamphlets and Small Booklets

- A. Pamphlet binders with four-flap inner enclosures provide maximum protection from abrasion when items are inserted and removed.**

Most pamphlet binders can be stored upright, provided there is adequate support from adjacent volumes.

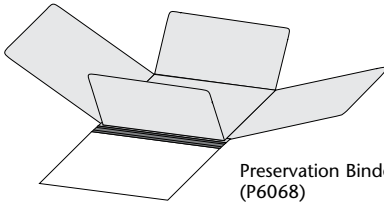

Preservation Binder  
(P6068)

- B. Envelopes may also be used for pamphlets, but fragile pamphlets require the protection of a paper folder or envelope sling before being placed into the envelope.**

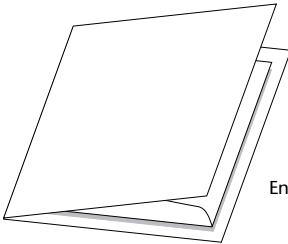

Envelope Storage Binder

Choose envelopes that are large enough to allow the pamphlet to be inserted and removed without damage. See page nine for descriptions of envelopes and inner folders. If items in envelopes need to be shelved with books, use envelope storage binders (EB811) or Pocket Binders (Y1) to provide support.

- C. If envelope storage binders are not used, envelopes should be stored in boxes.**

Use an adjustable spacer for partially filled boxes. Pamphlet boxes with flip tops (or crocodile boxes) (9105/LEFCROC3) provide upright storage. Average sized pamphlets can also be treated like documents (pages 11–12) and placed in file folders in pamphlet boxes (9105). This treatment is typically used when the pamphlets are part of a larger archival collection.

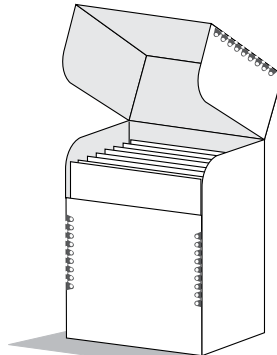

Pamphlet Box



Document  
Preservation Binders



Four-Flap Enclosure



Envelope Storage  
Binders



Pocket Binders



Flip-Top  
Pamphlet Boxes

**Please Note:** Product number references in text and photos along outside column all represent Gaylord product groups. Additional sizes, colors, etc. may be available. Please go to [Gaylord.com](http://Gaylord.com) and use product number or keyword description to find full selection.



Open Pamphlet Files



Newspaper Boxes



Newspaper Sleeves



Comic Book Envelopes &amp; Stiffeners



Ziplock Bags

**D. Open pamphlet files are suitable for temporary storage only.**

They allow easy retrieval, but do not provide adequate mechanical support for long-term storage, nor do they protect items from light and fluctuations in the environment.

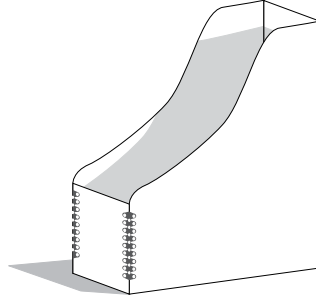
Open Pamphlet Files  
(PP963)

## CASE STUDY V: PERIODICALS & NEWSPAPERS

**Scope:** Unbound Periodicals & Newspapers

- A. Collections of periodicals and newspapers should be stored flat in sturdy boxes because of their size and weight.** The box depth should be shallower for contents that are heavy. When in good condition, issues can be placed directly into boxes. Polyester sleeves are available in large format sizes for newspapers (NS1218) and will provide long-term protection in flat storage. Adjustable spacers should be used to avoid slippage and sagging.

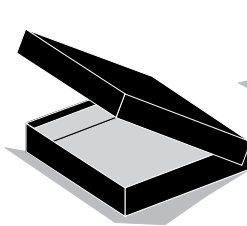

Clamshell Box (CL12103)

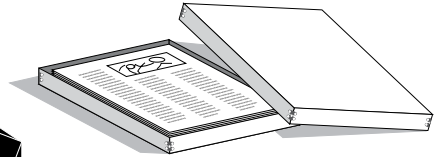

Flat Storage Box (NB18133)

- B. Single issues of average size may be treated as pamphlets** (page 13).
- C. Thin and fragile items require additional protection.** They should be inserted into folders and envelopes before being put into boxes. See pages eight and nine for information about selecting folders and envelopes.
- D. Polyethylene bags (Z46) provide temporary protection, especially when the items are subjected to excessive handling.** Collectors and dealers may find these particularly useful. However, given the evidence that acidic paper appears to deteriorate more rapidly when encapsulated, it is not advisable to use sealed bags for permanent storage of acidic materials. If comic books must be stored so that they can be viewed, polyethylene envelopes with buffered stiffener boards (ESB610/BS610A) are available.
- E. Open pamphlet files may be used for short-term storage of periodicals in good condition.** The files allow easy retrieval, but they do not provide adequate support for long-term storage, nor do they protect periodicals without enclosures from light and dust.



## CASE STUDY VI: EPHEMERA

Collections of paper ephemera provide the greatest challenge of all. Often size varies, the paper stock is poor, and people want to see the object itself. Common ephemera include postcards, greeting cards, brochures and stereo views.

- A. Collections of ephemera can be stored according to the recommendations for archival documents and pamphlets** (see Case Studies I and IV). Before being placed in folders, fragile or small items should be placed in paper folders, envelope slings or individual polyester enclosures for protection. Polyester enclosures are useful for any items that will be frequently handled. Where possible, ephemera should be sorted and stored by type and size, to prevent damage due to differing sizes and weights.
- B. Collections of materials in a single format can be stored in polyester envelopes in appropriately sized boxes.**

Postcard Sleeves  
(PC35/PB35)  
& Storage Boxes  
(51097)

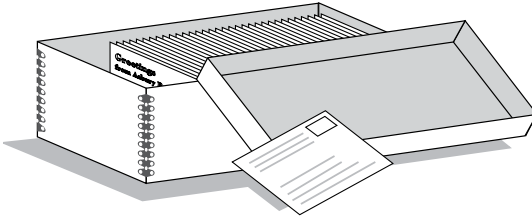

- C. Albums and scrapbooks made of stable materials are another alternative for ephemera collections, especially for private collectors.** A variety of 3-ring albums with plastic album pages (K12112) and scrapbooks (FTM-125-01) and scrapbook pages (62227) made from non-damaging materials are available.

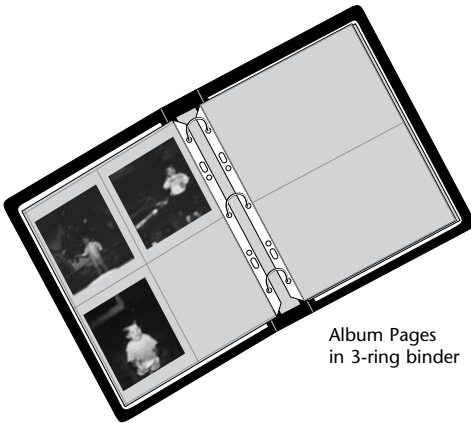

Album Pages  
in 3-ring binder

Never attach ephemera with pressure-sensitive tapes, rubber cement or damaging glues. Individual items can be attached to acid-free or buffered mounting paper (9X11CRB) using photo corners (A224).

When objects have been mounted onto pages, they can be placed into polyester page protectors (sealed on one side) (BA811), polyester sheet pockets (sealed on three sides) (DM811), or polypropylene sheet protectors (sealed on three sides) (62013). Alternatively, polypropylene pages with various sizes of individual pockets (PP45-8) are available; these are designed for popular sizes of photographs, but may also be appropriate for small ephemera. If an ephemera collection includes photographs, remember that any enclosures or pages that are to be used with photographs must pass the Photographic Activity Test.

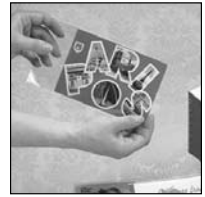

Postcard Sleeves

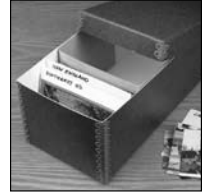

Postcard Boxes



Memory Scrapbook



Album Pages

**Please Note:** Product number references in text and photos along outside column all represent Gaylord product groups. Additional sizes, colors, etc. may be available. Please go to [Gaylord.com](http://Gaylord.com) and use product number or keyword description to find full selection.

## CASE STUDY VII: BOOKS AND OTHER BOUND MATERIALS

**Scope:** Valuable and fragile books and other bound materials that require protection.

Book bindings are intended to protect the textblock, but sometimes the bindings themselves are so fragile or valuable that the books themselves require protective enclosures. Examples include: rare books that need additional protection against environmental pollution and light; fragile books that cannot stand upright on a bookshelf without sustaining damage; brittle books with loose pages; and damaged books that need temporary protection until a conservator can review and treat them. As more and more libraries rely on off-site storage, sturdy enclosures are also needed to protect items in transit.

Following are several options for protecting books and other bound materials. Ideally, enclosures should be custom-fit so that the items are not damaged by being jostled in the boxes. If a custom-made box is not possible, acid-free tissue paper can be used to fill the box around the volume.

- A. Custom-sized rare book boxes provide maximum protection. Gaylord carries a selection ranging from pre-scored folder stock enclosures for lightweight books (BX623) to sets of acid-free corrugated board that can be scored to create rare book boxes (EFB622) that are custom fit for larger or heavier books. A third alternative is a pre-made rare book clamshell storage box (RBP1) that comes with a supply of unbuffered tissue to wrap the book and gold title labels for the outside of the box.

### HOW TO CONSTRUCT RARE BOOK BOXES

1. Select board of appropriate width, crease with scoring wheel, fold over book, and attach VELCRO® Brand Velcoins®.

2. Select board of appropriate height.

3. Place second board around book and attach VELCRO® Brand Velcoins®.

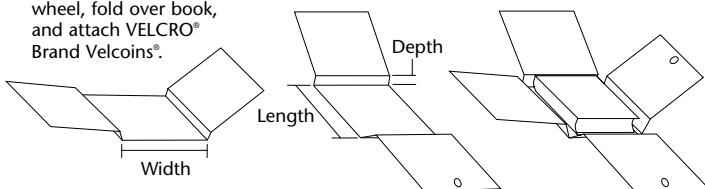

- B. **Tying and wrapping are less expensive options.** These are short-term solutions for items that need repair or treatment by a conservator. They also provide protection for less valuable items that are being sent to off-site storage. Wrap book in acid-free tissue (UT30405) or wrapping paper (WP38) and tie with cloth pull fasteners (GTW18) or cloth tying tape (CT100).

- C. **Phase boxes are the traditional storage containers for library books.** Directions for making them can be found in the manuals on page 60. Gaylord provides all the materials required to make phase boxes, including 60-pt. blue/grey board (BG1620), washers (HDP34) and rivets (FASTENERS-KIT).

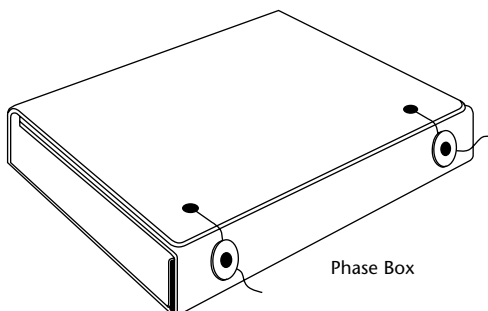

Phase Box



Rare Book Boxes



Curator Rare Book Boxes



Easy Rare Book Boxes



Cloth Pull Fasteners



Custom Rare Book Boxes

**D. Book Jackets provide effective protection for book covers that are either valuable or vulnerable.** Examples include books with modern dust jackets in private collections, bindings that would be damaged by fingerprints, and deteriorated leather bindings with “red rot\*” that could spread to adjacent books. Gaylord’s pre-made jacket covers of 2mil polyester with acid-free paper backing (GF9P/GF9PT) would be suitable for modern books with dust jackets. Custom-sized polyester jackets can be made for hardcover books from Melinex® (410122). Do not use glue to attach the jacket cover to your book. If you use tape to attach the covers, apply from cover to cover. Do not apply tape to the bookbinding itself.





Wrapping Paper



Book Covers

## MAKING POLYESTER BOOK JACKETS:

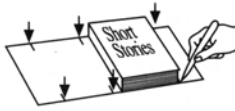
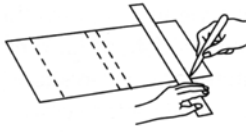
1. Cut a strip of Melinex Polyester film to height of textblock and three times textblock width plus book's thickness. 
2. Wrap the film around book so that ends are even. 
3. Using bone or Teflon® folder, crease marks along fore-edge of book covers. Make crease marks at edge of spine, making sure Melinex film does not shift on book. 
4. On a cutting mat or other soft surface, line ruler up with dent marks and use folder to crease Melinex film, making sure creases are parallel. Fold along lines using folder to ensure fold is sharp. 

\* Red rot is a disintegration of the leather into a red powder. Gaylord carries the product Cellugel (CLGLP) that consolidates the rotted leather so that the deteriorating book cover may safely be handled without danger of breathing the loose leather dust or soiling hands and clothes. However, it is recommended that you consult with a professional conservator on the proper use of Cellugel. In the interim, cover with a Melinex book cover, as described above, or isolate the book in a separate rare book storage box (EFB622).

**Please Note:** Product number references in text and photos along outside column all represent Gaylord product groups. Additional sizes, colors, etc. may be available. Please go to [Gaylord.com](http://Gaylord.com) and use product number or keyword description to find full selection.

# 2

## SECTION

# Archival Storage of Photographic Materials

<b>Introduction</b>	<b>18</b>
<b>Selecting Storage Materials</b>	
Paper Enclosures	<b>19</b>
Glassine	<b>19</b>
Interleaving Paper Board	<b>19</b>
Mat Board	<b>19</b>
Plastic	<b>19</b>
<b>Standards &amp; Testing</b>	<b>20</b>
<b>Preparing Collections</b>	<b>21</b>
<b>The Storage Environment</b>	<b>22</b>
<b>Case Studies</b>	
I: Photographs—Unmounted	<b>24</b>
II: Photographs in Albums	<b>27</b>
III: Mounted & Matted Photographs	<b>28</b>
IV: Other Formats	<b>30</b>
V: Negatives	<b>31</b>
VI: Digital Output	<b>34</b>
VII: Optical Disks	<b>35</b>

## Introduction

Photographs are found throughout our museums, libraries, historical societies, archives and our homes. Often taken for granted, photographs are actually fragile and easily damaged. Fading, stains, distortion and other physical changes are signs of their deterioration. Unfortunately, deterioration is often the result of the inherent instability of certain photographic processes and materials—cellulose acetate negatives, nitrate negatives and color slides and prints, for example. While the nature of our collections may be outside our control, deterioration can also be initiated or hastened by poor storage conditions and display techniques, which are our responsibility. The goal of this section is to provide the preliminary background information necessary to select appropriate storage materials for photographic collections. People with small personal collections may find this pamphlet adequate for their needs. Professional photographers, curators, archivists, and dealers will need to read further if they are to develop appropriate preservation programs. Fortunately, a number of excellent books are now available and are listed on pages 58–59.

No amount of reading, however, can provide all the answers if your collections are extensive, in poor condition, or include valuable works of art and rare examples of early photographic processes. Professional photographic conservators have the technical expertise to assess the condition of photographs and make recommendations for their storage and treatment. The American Institute for Conservation (202-452-9545) ([info@aic-faic.org](mailto:info@aic-faic.org) or [www.conservation-us.org](http://www.conservation-us.org)) can provide the names of conservators in your region as part of their free referral service.

This section reflects our current understanding of the storage requirements of photographs. It will be revised as new information and products become available. Unless noted otherwise, all of the items illustrated in this section are available from Gaylord. Call 1-800-448-6160 for a free Catalog or visit [Gaylord.com](http://Gaylord.com).

## Selecting Materials

Storing your collection in appropriate envelopes, sleeves, albums, and boxes is fundamental to their preservation. These enclosures make photographs last longer because they protect against light, dust, handling, air pollutants and rapid fluctuations in temperature and humidity. They must be made of materials that are strong, durable and chemically stable if they are to provide long-term protection.

Suitable materials for the storage of photographs and negatives are now available, but buyers should use judgment and select a supplier who specializes in products for archival use. Suppliers' claims of "archival quality" in their catalogs and advertisements should be substantiated by product descriptions and test results that provide adequate technical information. Materials that come in contact with photographs should pass the Photographic Activity Test (PAT), ISO 18916 (ANSI/NAPM IT9.16), an accelerated aging test that verifies that they are non-damaging to sensitive photographic materials. This test has been approved by the National Association of Photographic Manufacturers.

**Paper**—Since poor quality folders and envelopes can hasten the deterioration of photographs and negatives, it is essential that paper be free of acidic compounds such as those found in alum-rosin sizing and unpurified wood pulp. It is also important that the paper and boards used to store photographs have very low levels of lignin (less than 1%) because lignin can cause staining and fading.

Acidity and alkalinity are measured by pH, using a logarithmic scale of 0–14, where 7 is neutral. Paper should not have a pH below 7. In most cases, choose a paper that has a pH of 7.5 to 9 and an alkaline reserve of 2-3% calcium carbonate, which will neutralize acid contaminants that come in contact with the paper. Some photographic processes, however, will react to alkaline environments. For these materials, unbuffered paper with pH 7 to 7.5 is best for envelopes and folders. In summary:

All papers used to store photographs should pass the Photographic Activity Test. Nitrate and cellulose acetate film should be stored in buffered paper. Unbuffered paper should be used for cyanotypes, including architectural blueprints and dye transfer prints. The current ANSI Standard recommends unbuffered paper for color photographs and color negatives; buffered paper for black and white photographs and negatives.

Paper has advantages for storing photographic materials. Its opacity protects images from light and provides a surface for written information. Its porosity prevents the accumulation of moisture or harmful gases. However, items must be removed from paper enclosures to be seen, increasing the chance of mishandling and abrasion.



Look for this icon when selecting paper storage products for photographs and negatives.

**Paper Enclosures**—Enclosures should protect items from dust and handling, and provide physical support. Envelopes should be sealed on the edge with an inert adhesive. Adhesive-free paper enclosures, including folders (RFW9115) and four-flap enclosures (4F45), are available.

**Glassine**—Although it has been the traditional material for storing negatives and for interleaving, glassine is no longer recommended for use with photographic materials. Buffering causes glassine to lose its translucency, and the thin unbuffered paper quickly absorbs environmental acids and moisture.

**Interleaving Paper**—A soft, smooth paper can be used to interleave photographic prints that are not placed in individual sleeves and to protect the surface of matted prints. Interleaving paper (P810B/PB811) provides a barrier against dust and abrasion during storage and use.

**Board**—Like paper, board can be manufactured to be free of acids. The board used for most archival storage boxes is 60 points (60mil) thick or 40 points thick. Tan barrier should pass the Photo Activity Test.

Storage boxes (PB1083/PB573) made of barrier board should be sturdy enough to support their contents and have reinforced corners. Snug covers will prevent dust and pollutants from entering. Boxes are available in a range of styles, which are illustrated in the Case Studies at the end of this section.

**Mat Board**—When matting and framing photographs, use conservation board of cotton fiber (RBW21114) or purified wood pulp (RCMBW21114). These boards are available in two-, four- and eight-ply thicknesses. The heavier weights are recommended for oversized photographs that need extra support.

**Plastic**—Clear plastic enclosures are particularly useful for photographs and negatives that receive continual handling and viewing. Plastics must be chemically stable, free of additives and abrasive surface coatings.



Unbuffered  
File Folders



Four-Flap  
Negative Enclosures



Interleaving Paper



Drop-Front  
Storage Box

**Please Note:** Product number references in text and photos along outside column all represent Gaylord product groups. Additional sizes, colors, etc. may be available. Please go to [Gaylord.com](http://Gaylord.com) and use product number or keyword description to find full selection.



Self-Locking  
Print Sleeves



Album Pages—  
Polypropylene



Negative & Print  
Envelopes—  
Polyethylene

Plastics manufactured for commercial packaging, for example, often contain additives that react with oxygen and light to produce harmful chemical compounds that can damage photographic materials. Unfortunately, it is difficult to distinguish plastics with additives or surface coatings by look or touch. The best guarantee of quality is to purchase enclosures from a recognized supplier of archival materials.

### Three types of plastics are currently considered acceptable for long-term storage:

- 1. Polyester**—Melinex® is a brand of polyester that meets the requirements of long term storage of photographic materials. Clear, smooth, and rigid, polyester gives support while letting users see the image. Dupont Mylar® Type D, an acceptable brand of polyester, has been discontinued.
- 2. Polypropylene**—Untreated (uncoated) polypropylene is an acceptable low-cost alternative to polyester. It is less rigid but is clear, and can be used for photographic materials that do not need the greater support provided by polyester; or where the greater cost of polyester cannot be justified. Avoid polypropylene that has a surface coating applied.
- 3. Polyethylene**—The softest of the plastics and the least clear. High-density polyethylene is translucent, like glassine, and its smooth surface is the least likely to cause surface abrasion. Like polypropylene, it is a lower cost alternative to polyester, where the clarity and rigidity of polyester is not needed.

Vinyl pages and some “magnetic photo albums” are unacceptable for the storage of photographs. Sheets and enclosures made of polyvinyl chloride (also called PVC or vinyl) are recognizable by their oily feel and smell. They release chemicals that react with photographic materials to cause staining and deterioration. Many older style “magnetic albums” have poor quality backing pages, coated with a tacky adhesive, that may cause discoloration and make it difficult to remove photographs in the future. Cellulose triacetate is not recommended for long-term storage because it becomes distorted and can cause surface abrasion.

**Plastic Enclosures**—Several types of enclosures, made from the three safe plastics, are available. Unlike paper, plastic allows users to view the image without removing it. Ultrasonic or heat-sealed seams eliminate problems from adhesives, and the plastic protects the image from moisture and pollutants. Some of the most common enclosure types are folders (6255AL), envelopes (PN45/PNP45), sleeves and storage pages (PP45-8) for three-ring binders. These will be described in more detail in the Case Studies beginning on page 24.

## Standards & Testing

The American National Standards Institute (ANSI) and the International Organization for Standardization (ISO) have developed technical standards for photographic materials, processing and storage. These include:

1. American Standards for Imaging Materials—*Processed Photographic Films, Plates, and Papers—Filing Enclosures and Storage Containers*, ISO 18902, (ISO old number 10214), ANSI/NAPM IT9.2
2. American National Standard for Imaging Materials—*Processed Safety Photographic Films—Storage Practices*, ISO 18911, (ISO old number 5466), ANSI/ NAPM IT9.11

3. American Standards for Imaging Materials—*Processed Photographic Materials—Photographic Activity Test*, ISO 18916, (ISO old number 14523), ANSI/NAPM IT9.16
4. American Standards for Imaging Materials—*Polyester Base Magnetic Tape—Storage Practice*, ISO 18923, (ISO old number 15524), ANSI/NAPM IT9.23
5. American Standards for Imaging Materials—*Optical Disk Media—Storage* ISO 18925, (ISO old number 16111), ANSI/NAPMIT9.25

Adherence to standards rests with the supplier. Gaylord's archival products are manufactured to the most current standards established by ANSI and ISO, and to the specifications of institutions such as the National Archives and Records Administration and the Library of Congress Preservation Directorate. Information and specifications about their products are available from Gaylord.

For quality assurance, Gaylord maintains an independent testing program. Samples of photographic storage materials are periodically sent to the Image Permanence Institute in Rochester, New York, where the Photographic Activity Test is administered. Tested materials include box board, album pages, envelopes, and folders. Results are available on request.



White  
Cotton Gloves



Anti-Static Gloves

## Preparing Collections

Before selecting storage materials, you will want to evaluate your collection from several points of view. For the family collection, this may be as simple as sorting photographs on the dining room table. For the large institution, a survey may be required.

1. **Assess the value of your collection.** Are the photographs unique? Do negatives exist to make duplicates? Are the prints valuable as works of art or as historical documents? These answers will help set priorities and budgets.
2. **List the types of formats, sizes, and quantities of items in your collection** so that you can select appropriate types and amounts of storage materials.
3. **Anticipate the use the collection will receive.** Who will use the photographs? How often? Heavily used collections will need extra protection, especially if materials are to be handled without supervision.
4. **Obtain copies of unique or important images.** Good quality copy prints are useful for display, for added security, and for sharing with others. Larger portrait studios and photography shops can provide copy services for reasonable rates.

**Follow these guidelines as you prepare your collection for storage:**

1. **Handle prints and negatives along the edges, preferably wearing white cotton gloves (71200).** Dirt, dust, and oils from your fingers can cause permanent damage.
2. **Remove photographs and negatives from poor quality enclosures if it is possible to do so without causing damage.** Remember to keep all information from the old pages. If prints are dry mounted or glued to old album pages and mats, do not attempt to do the work yourself. Place the entire page in a folder or plastic sleeve.

**Please Note:** Product number references in text and photos along outside column all represent Gaylord product groups. Additional sizes, colors, etc. may be available. Please go to [Gaylord.com](http://Gaylord.com) and use product number or keyword description to find full selection.



Pigma Pen



Film Marking Pen



Blue Marking Pencil

3. **Remove extraneous materials such as paper clips, rubber bands, old clippings, and notes.** If important, these can be placed in envelopes and stored separately. Newspaper clippings should be photocopied onto alkaline paper.
4. **Note any badly damaged items, place them within individual folders, and set them aside for professional conservation treatment.** Do not undertake any "first aid", and never use pressure-sensitive tapes or glues to mend photographs. It is far better to make a copy print and store the damaged original.
5. **Whenever possible, place identifying information on the enclosures rather than on the photographs themselves.** Use a No. 2 pencil, Pigma pen (XSDK08-49), or India ink on paper, and a film-marking pen (202040) on plastic. Felt tipped pens and ball point pens should never be used because the ink can "bleed through" and stain the photograph. Use labels with a stable adhesive on boxes and folders.
6. **If it is necessary to have identification on the photograph itself, write brief notations lightly on the back with a lead pencil (No. 2 or softer).** If the surface of resin coated paper does not accept pencil, use a blue photo marking pencil (PC919) or a film marking pen to write on the back edge of the print.

## The Storage Environment

Once photographs have been placed in enclosures, they should be stored in an environment that is dark, cool and dry. Research has proven that high humidity and temperatures will accelerate deterioration in films and prints. Silver images (black and white photographs) are affected primarily by humidity and contaminants from poor quality enclosures or air pollution. Color photographs are sensitive to light, heat and humidity. Light is such a threat to color prints that it is best to have a second copy (kept in the dark) of any color prints that are displayed for long periods. Prolonged damp conditions (relative humidity over 65%) can lead to mold growth on photographs. Fluctuations in temperature and humidity may cause yellowing or staining to digital prints, as well as color bleeding. Ozone and other pollutants may cause image deterioration, particularly with dye images on microporous coating. Protect optical disks from scratches, abrasions, dust and pollutants. Corrosion of the metallic surface and mold growth may occur on disks due to high humidity.

Achieving an acceptable environment is critical if photographs are to survive. For families, this means removing photographs from damp basements and overheated attics. A shelf in a dark closet on the main floor is often the best location available in a home. When storage conditions are less than ideal, it becomes even more important to provide enclosures and boxes that buffer the photographs from the deleterious effects of the environment.

Institutions must ensure more extensive environmental controls. The International Standard Organization provides up-to-date information concerning the care and handling of photographs. Since photographs, including negatives, are made with various materials, it is difficult to provide uniform storage recommendations for all formats. The Image Permanence Institute has created a *Storage Guide for Acetate Film (SGAF)*, based on the recommendations from the International Standard Organization. This guide provides the ISO standards and also includes a simplified version to assist in the long-term preservation. For the simplified version, reference to cool and cold for this context can be translated as: 54°F (12°C) and 40°F (4°C), respectively.



**Photographic film: black-and-white and color**

Maximum temperature depends on maximum RH.

Simplified: cold with maximum 50% RH.

**Black-and-white prints**

Maximum temperature 64°F (18°C), for maximum 50% RH.

Simplified: cool with maximum 50% RH.

**Color prints**

Maximum temperature depends on maximum RH.

27°F (-3°C) maximum temperature for maximum 50% RH.

36°F (2°C) maximum temperature for maximum 40% RH.

Simplified: cold with maximum 50% RH.

**Digital Output**

ISO has not yet established storage recommendations specific to inkjet prints. Until it does, the conditions specified for color photographic prints apply to ink jet.

**Optical disks**

70°F (21°C) for maximum 50% RH.

Simplified: cool and cold considered optimum. Frozen not recommended because of concerns about layer separation.

Institutions with substantial collections of photographic negatives and prints will want to segregate these materials to provide optimum conditions for long-term preservation. Institutions that cannot store photographs, documents, manuscripts, and books separately will need to compromise.

Control of contaminants and pollutants is also recommended. This involves effective air circulation and filtration to remove gaseous pollutants and particulate matter from incoming air. For more information about environmental issues, consult *Conservation Environment Guidelines for Libraries and Archives*, the *IPI Storage Guide for Acetate Film*, *IPI Media Storage Quick Reference*, and *The Permanence and Care of Color Photographs* (see page 59). The last citation includes detailed information about cold storage of archival collections of color prints and negatives.



Preservation  
Environment Monitor

**Please Note:** Product number references in text and photos along outside column all represent Gaylord product groups. Additional sizes, colors, etc. may be available. Please go to [Gaylord.com](http://Gaylord.com) and use product number or keyword description to find full selection.

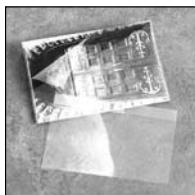

Self-Locking Sleeves



Sheet Protectors



Album Pages

## Case Studies

Selecting specific envelopes, albums, and boxes requires careful consideration. Physical condition, size of collection, anticipated use, and budget all play a part in developing a strategy. Section 2 presents several case studies to show how the products available from Gaylord can be used to store photographic prints and negatives. If the photographs are part of a larger archival collection, consult Section 1: Archival Storage of Paper for additional information.

### CASE STUDY I: PHOTOGRAPHS—UNMOUNTED

**Scope:** Standard Size Unmounted Photographic Prints, (black & white and color). (See Case Study III for details about storing mounted photographs.)

**A. Select appropriate primary enclosures made of chemically stable and durable materials that will protect the photographs and not cause damage.** All storage materials should pass the Photo Activity Test. Unless the prints have little value or are consulted infrequently, it is best to place each print into an individual enclosure.

1. *Photographs that are viewed often may be placed in plastic enclosures that allow the image to be readily seen.* Because of its rigidity, polyester provides better support for prints that are fragile or on thin paper. However, it should be avoided for prints with flaking emulsion that could be lifted by static electricity. Very fragile prints may need the additional support of acid-free board.

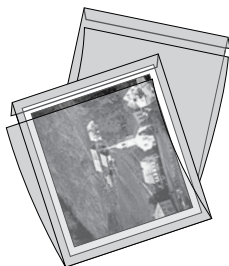

Both Melinex® (CDVS24) and polypropylene (FL45N) have a self-locking top flap that allows the sleeve to be opened completely, eliminating possibility of abrasion during insertion.

Photo/Print Album Pages (PP45-8) are made of polypropylene and have pockets for a range of print sizes.

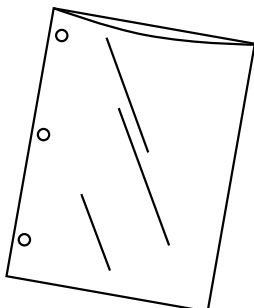

8 x 10" prints fit comfortably in Melinex® Sheet Protectors (DM811) that are three-hole punched for storage in a ring binder.

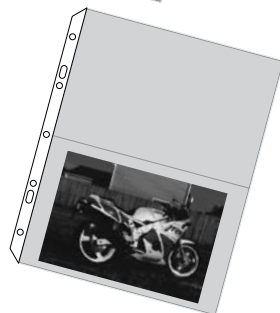

2. *Photographs may be placed directly into paper enclosures.* If this option is selected, the paper should be pH neutral and unbuffered for color prints, alkaline/buffered for black and white prints. Enclosures come in a range of styles. Avoid envelopes with center seams and select those with seams along the bottom and side, sealed with a stable adhesive.

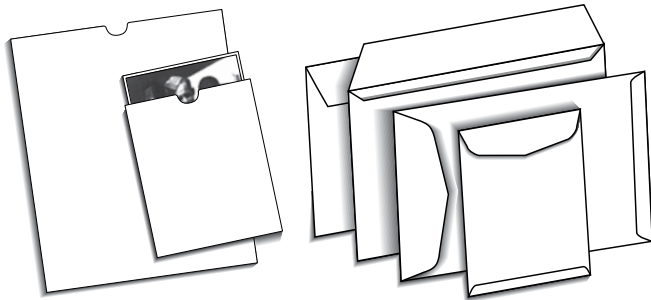

Print Envelopes with a thumb-cut (PB45/NP45) opening make insertion easy. Envelopes with top and side opening keep out dust.

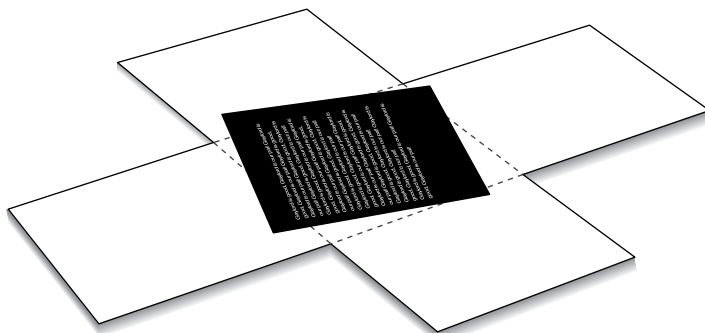

Four-Flap Negative Enclosures (4F45) can also be used for storing prints. Their design eliminates all adhesives, and the flaps provide additional support for print, but they do take up more space.

3. *If the photographs are going to be boxed without enclosures, place interleaving paper between the prints.*

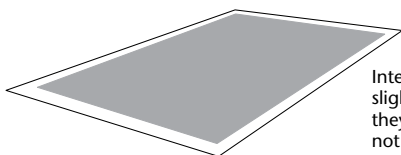

Interleaving sheets (P810B) should be slightly smaller than the prints so that they cover the image completely and do not project beyond their edges.

- B. Place sleeves or envelopes in folders or boxes that are made of paper or board that is acid-free, has a low lignin content, and passes the Photographic Activity Test.** It is best to group photographs of similar sizes together in standard sized enclosures so that they provide even support for each other.



Negative & Print Envelopes



Negative & Print Envelope without Thumb-cut



Four-Flap Negative Enclosures

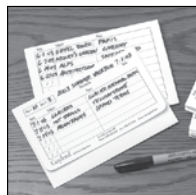

Print Envelopes for Snapshots

**Please Note:** Product number references in text and photos along outside column all represent Gaylord product groups. Additional sizes, colors, etc. may be available. Please go to [Gaylord.com](http://Gaylord.com) and use product number or keyword description to find full selection.



Negative & Print Boxes



Print Boxes—  
Drop-Front, Flip-Top



Hanging Folders

1. *Storage boxes should be strong, have reinforced corners, and match the size of the prints.* A range of styles is available, depending upon the size and condition of the prints. For digital prints, to avoid pressure in a stack situation, place only a few prints in archival boxes or folders.

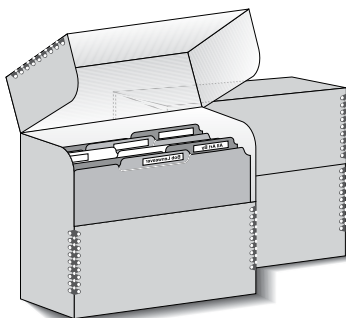

If standard Document Cases (D12102) are selected for vertical storage, it is important to fill the box or use Spacers (EFCB821) so that the prints receive adequate support and do not curl or become distorted. The box should not be so full, however, that it is difficult to remove material. File folders (RF9115/RFW9115) or paper envelopes should be used to group prints and provide additional protection.

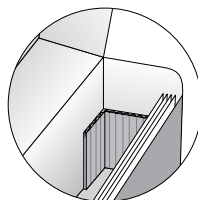

Another choice for vertical storage is a Shallow Lid Print Storage Box or Flip Top Storage Box (7105BK/EB1254), both of which are available in standard print sizes. This choice eliminates the problem of shifting and sliding that might occur in the larger document case.

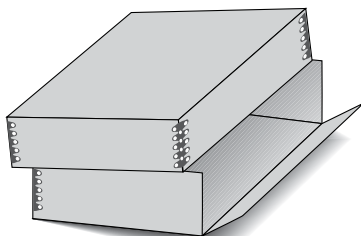
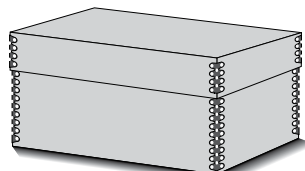

Drop-Front Storage Box (PB1083)

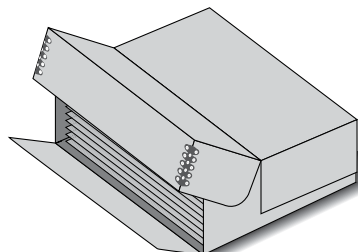

Drop-Front Box with hinged  
Flip-Top (ACDF1083)

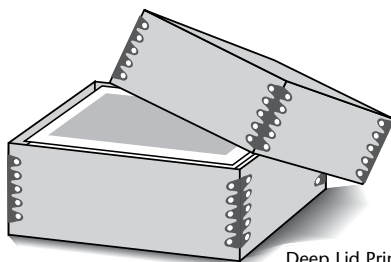

Deep Lid Print Box (FBB7)

Flat storage places less strain on the photographs and is especially recommended for fragile items. A variety of flat storage options are available.

2. *Acid-free hanging folders (HF9111-25) may be used for active collections that are consulted frequently.* Because they do not provide the additional protection against light and the environment that boxing does, hanging folders are not recommended for long-term archival storage.
3. *Prints stored in plastic sheet protectors can also be placed in 3-ring binders.* See Case Study II for details. As with hanging files, binders do not provide the protection of boxes and should not be used for fragile or rare prints.

## CASE STUDY II: PHOTOGRAPHS IN ALBUMS

**Scope:** Standard and Custom Size Unmounted Photographic Prints (black and white, color, digital)

Albums are the traditional format for organizing and preserving personal collections of photographs and memorabilia. Unfortunately, the papers and glues used in the past were usually acidic. Many “magnetic albums” have adhesives on poor quality backing pages that may cause prints to discolor and stick. Today, it is possible to purchase albums that will preserve your photographs for generations to come. Gaylord offers a range of options.

**A. Select an appropriately sized album made of chemically stable, durable materials.** Do not use any damaging glues or tapes to attach materials to the pages.

1. *If your photographs are standard sizes, the most cost effective method is to place the prints in polypropylene sheets with pockets (PP45-8) that correspond to print size.*

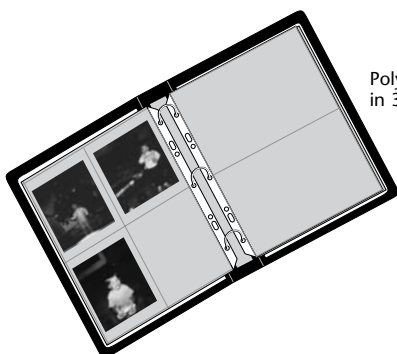

Polypropylene sheets  
in 3-ring binder album

2. *If you like a traditional look, select an album with paper sheets and polyester protectors (PPBA12112/40247). The paper should be pH neutral and thick enough to support the weight of the photographs.*



Secure photographs with corner mounts (A250). Cards, notes, and other paper ephemera should also be secured with corner mounts whenever possible, or hinged and tipped in with a stable reversible adhesive (52000/JTPSN). Substitute photocopies on alkaline paper (PB811) for news clippings. Never use pressure-sensitive tapes or rubber cement.

**B. If you have an older album that you want to preserve intact** because the prints cannot be removed without damage or because you don't want to lose the annotations or the original appearance, the best alternative is to place it in an alkaline/buffered box and store it flat. A box will protect the album from light and dust, and lessen the effects of pollution and handling.

1. *If photographs face each other or if the album includes unstable material like newsprint, place interleaving sheets between the pages*



Album Pages



Buckram Albums

**Please Note:** Product number references in text and photos along outside column all represent Gaylord product groups. Additional sizes, colors, etc. may be available. Please go to [Gaylord.com](http://Gaylord.com) and use product number or keyword description to find full selection.



Interleaving Paper

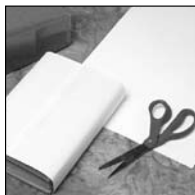

Wrapping Paper

Clamshell  
Archive Boxes

Drop-Front Boxes

as a barrier. Buffered (P810B) interleaving papers are available. Interleaving does, however, add bulk and should not be used if it strains the binding.

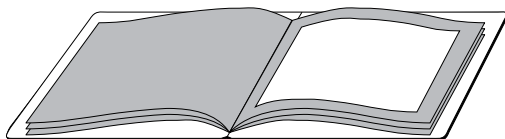

Interleaving paper should be slightly smaller than the album page but large enough to cover the photographs and inserts.

2. If the album is not used often and funding is limited, an inexpensive solution is to wrap it in alkaline/buffered paper (WP38) and store it flat.

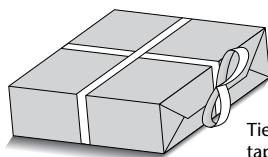
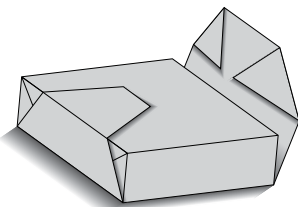

Tie with flat cotton tape (CT100).

3. If the album size corresponds to a standard size document storage box, place it in a clamshell (ACCL12103) or drop-front (PB1083) box so that the album can be removed without damage.

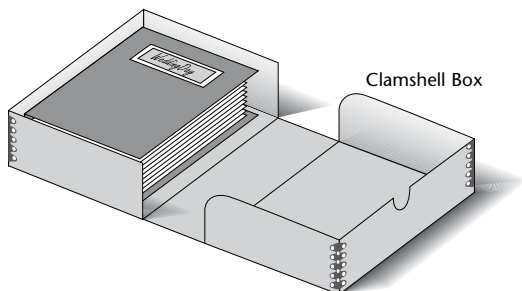

4. Boxes should fit properly. If a pre-made box is not available in an appropriate size, consider contacting a bookbinder who can make one. Be sure to specify that all materials, especially the inner box linings, are alkaline and buffered. This is an expensive option, usually reserved for rare and valuable albums.

## CASE STUDY III: MOUNTED AND MATTED PHOTOGRAPHS

**Scope:** Photographic Prints Mounted on Board and Unframed Photographic Prints in Window Mats

Many libraries have collections of photographs that were glued to cardboard for display, study and teaching. Albumen prints and other types of nineteenth century photographs were also mounted. Today these acidic mounts are often brittle and cracked along the edges but cannot be removed from their mounts without seriously damaging the prints. It is necessary, therefore, to store the prints in such a manner as to prevent any further deterioration.

At the same time, photographers continue to choose drymounting as the display technique for their work. Conservators do not recommend drymounting original art because the process is irreversible, even when museum quality board and heat-activated acrylic adhesives are used. However, collectors and museums still acquire prints that have been drymounted and need to store these prints safely.

Matting and framing are the preferred methods for displaying and storing valuable photographs. Prints are attached to an acid-free conservation board (RCMBW41114) via a reversible hinge and then covered with a window mat custom cut to display the photograph or print. Detailed descriptions of appropriate matting and framing techniques appear in *The Life of a Photograph* and *The Permanence and Care of Color Photographs* (see reference, page 59).

Section A and Section B.1 address the storage of permanently mounted photographic prints. Section B.2 discusses proper storage of matted prints.

**A. Select appropriate materials to protect the surface of the prints** and provide adequate physical support for the mounts.

1. If the mounted prints are consulted frequently, place them in polyester sleeves (CDVS24). If the mounts are sound and sturdy, you may use a lighter weight plastic like polypropylene sleeves (FL45N) or polyethylene thumb-cut envelopes (PNP45).

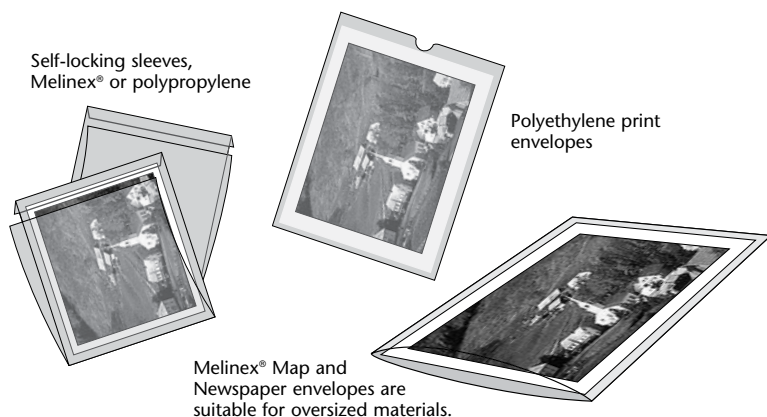

2. If the board is acidic and breaking, place the mount in a 4mil Melinex® envelope (M4104) with a piece of low-lignin board (UBT3040), slightly larger than the mount, behind it for support.

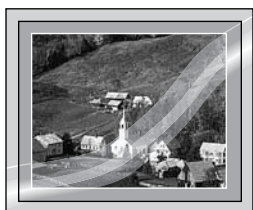

The board should be stiff enough to support the weight of the mount

3. If the mounted photographs are not used often or are not worth investing in sleeves, place interleaving paper over the surface of each print before boxing.

**B. Store mounted and matted photographs flat in acid-free boxes.**

1. Place mounted photographs in boxes that closely fit the size of the mounts.

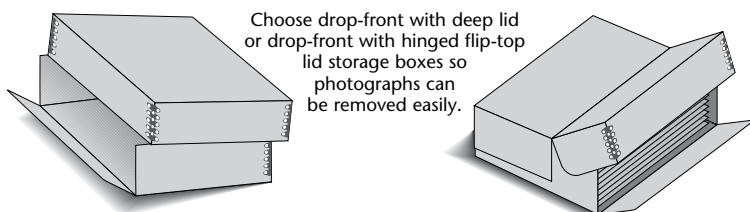

Pre-Cut Mats



Map & Poster Envelopes



4mil Melinex® Envelopes

**Please Note:** Product number references in text and photos along outside column all represent Gaylord product groups. Additional sizes, colors, etc. may be available. Please go to [Gaylord.com](http://Gaylord.com) and use product number or keyword description to find full selection.

Clamshell  
Portfolio BoxCard Boxes—Cabinet  
Cards & Carte de Visite

Stereo Box

2. *Matted photographs require sturdy boxes (PB10121/PBB10) that can support the extra weight of the mat board. Their inner depth should be only 1½ to 2 inches, to keep the weight manageable.*

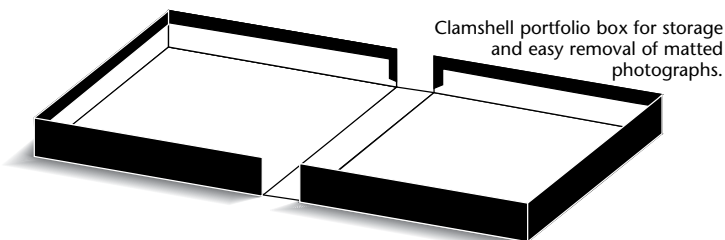
Clamshell portfolio box for storage  
and easy removal of matted  
photographs.

## CASE STUDY IV: OTHER FORMATS

**Scope:** Cartes de Visite, Cabinet Cards and Stereo Cards

During the second half of the nineteenth century, professional photographers produced a range of mounted photographs in smaller formats for the general public. Gaylord has developed polyester sleeves and boxes to fit the sizes of the most popular formats: Cartes de Visite, Cabinet Cards, and Stereo Cards. It is best to place these items in enclosures that are specially made to size rather than to put them in oversized enclosures where they may shift or fall out, causing abrasion and damage. For more details about the chemistry and preservation of these historical materials, consult *Care and Identification of 19th-Century Photographic Prints* (page 59).

- A. Place mounted photographs in polyester sleeves to protect the image surface.** Use self-locking polyester sleeves for Cartes de Visite (CDVS24) and Cabinet Cards (CCDS57); polyester sleeves with the two long sides sealed for Stereoscopic Cards (PN37A/PN47).

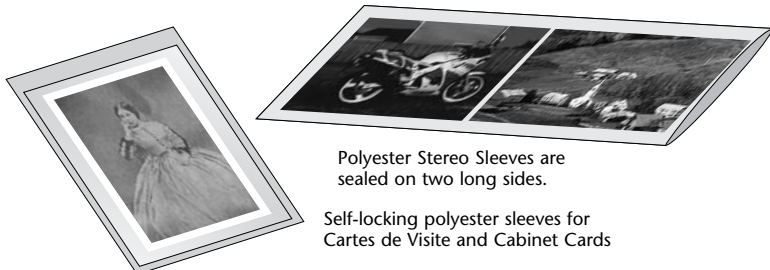
Polyester Stereo Sleeves are  
sealed on two long sides.Self-locking polyester sleeves for  
Cartes de Visite and Cabinet Cards

- B. Place sleeved cards in boxes made of low lignin alkaline buffered tan board.** Use Deep Lid Storage Box for Cartes de Visite (SP436), Flip-Top and Shallow-Lid Storage Boxes (CB755/EB1275) for Cabinet Cards. Stereo Boxes (B4712T) have a slant-back design that makes it easier to view the stereoscopic images.

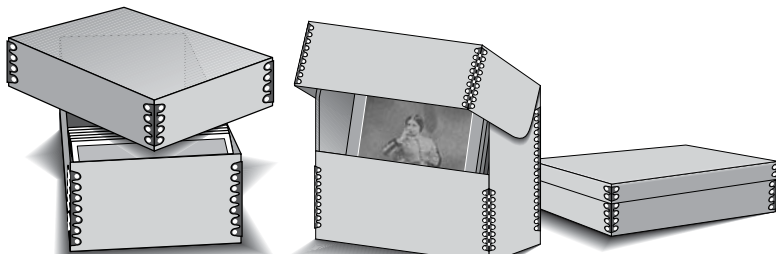
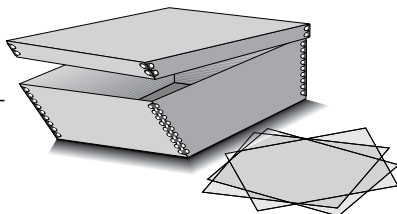
Deep Lid Storage Box  
for Cartes de VisiteFlip-Top and Shallow Lid Storage  
Boxes for Cabinet CardsStereo Storage  
Boxes with slant-  
back design for  
easy viewing



## CASE STUDY V: NEGATIVES

**Scope:** Film Negatives, (Black & White and Color) and Glass Plate Negatives

Glassplate negatives were popular from 1855 until the 1920s, and flexible plastic films were introduced around 1890. Nearly all films manufactured before the 1930s—and some made as late as 1950—have a highly flammable base of cellulose nitrate. Any film marked “Safety Film” is not nitrate and is non-flammable; it has a base made of cellulose acetate or polyester plastic. Most safety films (both color and black & white) have an acetate base, although the use of polyester has been increasing since the 1960s. Currently, polyester is used primarily for large-format negatives (4 x 5 inches, etc.), while 35mm and 120mm roll film are usually on an acetate base.

An important issue for film preservation is the inherent chemical stability of the plastic base. Nitrate and acetate are prone to decompose, release odors, and become crinkled, sticky, and generally unusable. When stored in warm, (or worse, warm and humid) conditions, the plastic base will deteriorate rapidly. In comparison, polyester film base is much more stable.

Because of their instability, nitrate and cellulose acetate should be placed in alkaline buffered paper envelopes and sleeves for long-term archival storage. Plastic enclosures can prevent the by-products of decomposition from escaping and cause these films to deteriorate more rapidly. If negatives show signs of deterioration, they should be duplicated onto stable polyester film. Cold storage with low or moderate relative humidity is recommended for the long-term storage of original cellulose acetate and cellulose nitrate negatives to retard further deterioration. It is especially important that cellulose nitrate be stored in a controlled environment with adequate ventilation because of the film’s instability and flammability. Cold storage is also recommended for color film.

See the *IPI Storage Guide for Acetate Film*, *Ritzenthaler’s Administration of Photographic Collections*, and *Wilhelm’s Permanence and Care of Color Photographs* (page 59) for details.

**A. Select paper enclosures that match the size of your negatives.** Strips of 35mm and 120mm film are placed in sleeves and larger format negatives are placed in individual envelopes. Both are available in buffered (PB45) and unbuffered (WE210) paper. Four-flap Negative Enclosures (4F45) eliminate all adhesives, and the flaps provide additional support for prints.

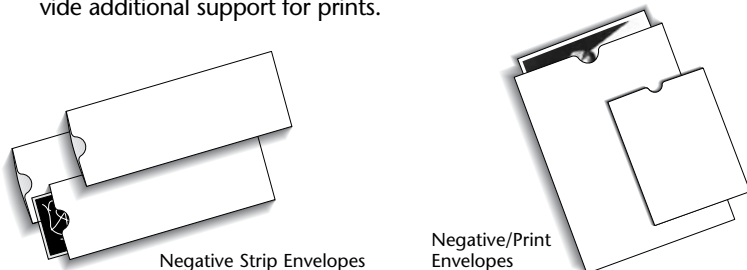

Negative Strip Envelopes

Negative/Print Envelopes

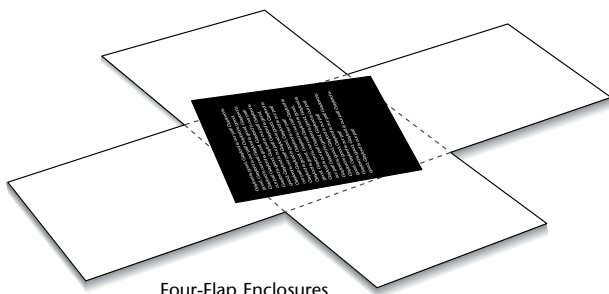

Four-Flap Enclosures



Negative Strip Envelopes



Negative & Print Envelopes



Lantern Slide Enclosures



Glass Plate Negative Boxes

**Please Note:** Product number references in text and photos along outside column all represent Gaylord product groups. Additional sizes, colors, etc. may be available. Please go to [Gaylord.com](http://Gaylord.com) and use product number or keyword description to find full selection.

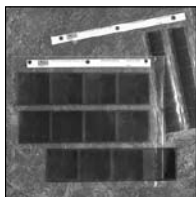

Negative Preservers



Negative &amp; Print Storage Kits

**B. Plastic enclosures come in a wide range of styles and materials.** They are particularly useful for collections that are used frequently because the images may be viewed without removing the negatives.

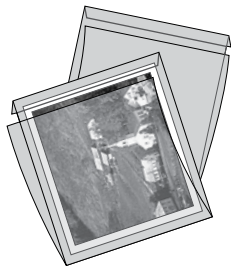

Both Melinex® (CDVS24) and polypropylene (FL45N) sleeves have a self-locking top flap that allows the sleeve to be opened completely, eliminating the possibility of abrasion during insertion.

Melinex® (PN45) or polyethylene (PNPL2225) sleeves for large format negatives are sealed on three sides and have a thumb-cut opening.

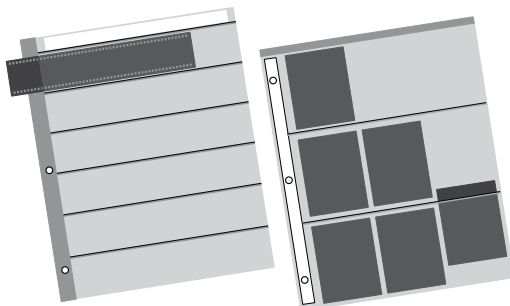

Polyethylene sheets (PFN4) with protective pockets are available for all size negatives.

**C. Plastic enclosures can be inserted into paper envelopes.**

This allows you to record cataloging information on the paper envelope.

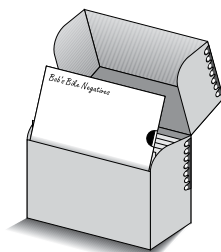
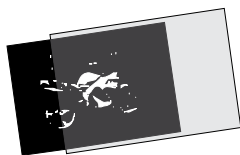

**D. Once in enclosures, negatives may be placed in boxes, binders, or hanging folders.**

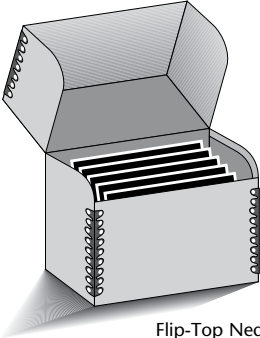

Flip-Top Negative Storage Box

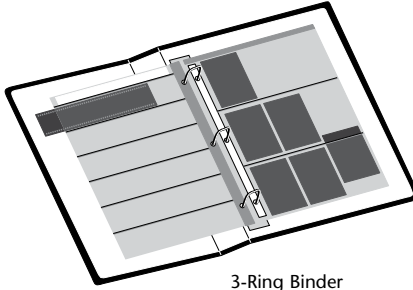

3-Ring Binder

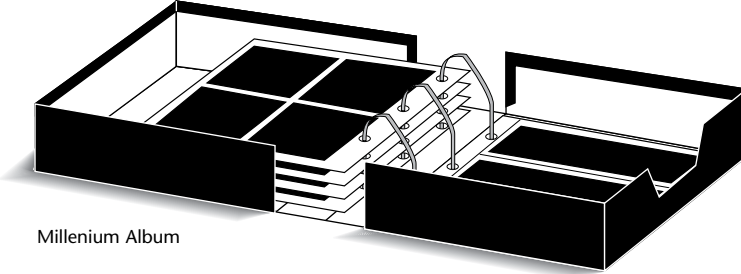

Millenium Album

**E. Glassplate negatives are extremely vulnerable to damage and require additional support.** Use Four-Flap Enclosures (4F571/4F8101) that are double-creased. Store vertically in sturdy Shallow Lid Storage Box (EB1254) sized to fit.

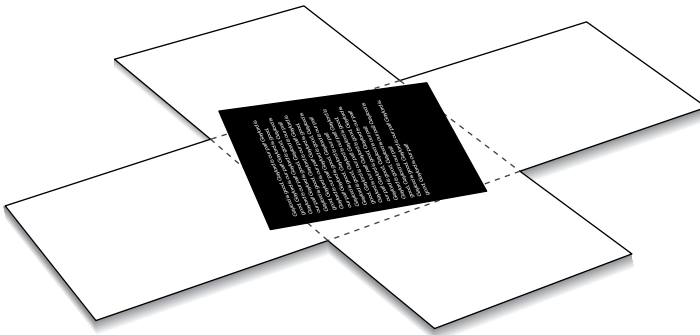

Use Four-Flap Enclosures that are double-creased to fold around the thickness of the plates

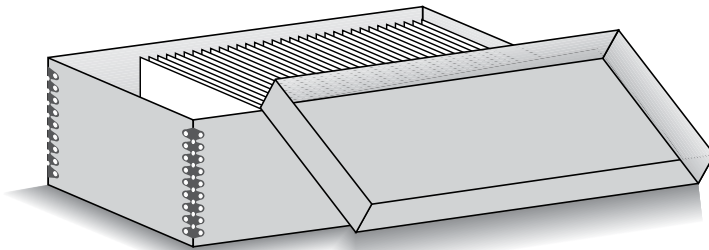

Store glass plate negatives in sturdy shallow lid storage box with rigid alkaline/buffered board dividers every five to 10 plates for extra support.



Negative Strip File Box

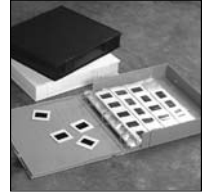

Binder Box Albums



Millenium Box Album



Four-Flap Negative Enclosures

**Please Note:** Product number references in text and photos along outside column all represent Gaylord product groups. Additional sizes, colors, etc. may be available. Please go to [Gaylord.com](http://Gaylord.com) and use product number or keyword description to find full selection.



Digital  
Print Boxes



CD Pocket  
Album Page



CD Preservers



CD Sleeve—Tyvek

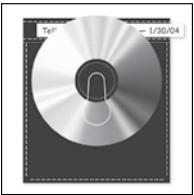

CD Sleeve—  
Polypropylene



Archival CDs & DVDs

## CASE STUDY VI: DIGITAL OUTPUT

**Scope:** Digital Photographs

Digital output is rapidly increasing as manufacturers consistently develop a variety of printing processes to generate graphic documentation, such as: office documents, books, posters, and both amateur and professional photographs, to name a few. The processes can range from: Fuji Pictography, Dye Diffusion Thermal Transfer, Liquid Ink Jet, Solid Ink Jet, Electrostatic, Direct Thermal, and Direct Thermal Transfer, to Dot Matrix. Generally, the color for digital output is made up of dyes or pigmented inks (the latter being the most stable). The paper support may be a plain (uncoated) paper, or have a swellable polymer coating (which protects the image from the environment), or a microporous coating (which has a faster drying time). There are many types of papers, inks, and dyes that are now accessible for the growing market. Because the products are continually changing, it is difficult to establish recommendations and standards. Previously, the standards for testing traditional material have been applied to evaluate digital output, but they do not address all problems related to this current technology. For instance, some digital prints are very sensitive to humidity, wetting, handling, and ozone. The ISO committee is aware of the need for appropriate test methods and is working on various issues, such as humidity-fastness, water-fastness, finger prints, indoor lighting, outdoor conditions, dark stability and gas fading.

For storage, in general, follow black and white photographic practices as described in this section. Gaylord has several products specifically designed for storage of digital prints. For primary enclosures, Presentation Pockets are available in 3mil (067-0811) and 8mil (065-0811) polypropylene. Melinex® L-sleeves (M1217L) will hold large format digital prints. Digital Print Boxes are available in black (DFB1217) or tan (DFT1217) and have a drop-front design for easy removal of prints.

## CASE STUDY VII: OPTICAL DISKS

**Scope:** CD-Rs (Photo CDs), CD-RWs, DVDs

There are various formats of optical disks, the most popular is the compact disk (CD) and the digital versatile disk (DVD). Optical disks can be divided into two categories. One type—audio compact disk (CD-A), DVD-ROMs and CD-ROMs (Read Only Memory), which are stamped from molds—is used for the publishing media and intended for mass production. The other type consists of writable disks on which the user can record individual data. There are two types of writable disks: those that cannot be modified after recording (CD-R, DVD-R) and rewritable disks (CD-RW), which can be modified after initial recording.

The structure of optical disks consists of complex layers. Disks are generally composed of three layers: a transparent polycarbonate plastic wafer, a reflective aluminum or gold layer, and a protective coating. Both recordable CDs (CD-Rs), and magneto-optical (MO) disks include an additional laser-sensitive coating. The even more complex structure of DVDs is made of two CDs bonded together.

Improper handling may cause rapid deterioration of CDs. Scratches can interfere with reading, particularly if they are around the circumference of the disk. During storage, environmental conditions play a considerable role in the media longevity. Because of the internal stresses which are caused during the fabrication of optical disks, rapid environmental changes can cause similar effects, such as cracks and delamination of the layers. To date, no stability studies have yet been published on the more complex structure of DVDs. ISO standard 18925 specifies storage conditions

for optical disks. These include avoiding temperature and relative humidity extremes and maintaining stable temperature and RH conditions. As with traditional materials, storing these disks in a dry, cool environment slows the degradation mechanisms. Pollutants may cause corrosion of the metallic reflective surface. The longevity of the CD-R depends on the CD itself (type of dye, metal layer, etc.) but also on the quality of the recording, which may differ from one CD burner to another. At least once every five years, the collection should be inspected for physical appearance and legibility.

**A. CDs and DVDs can be stored in polypropylene album pages (61918) for a safe, visible and organized storage.**

CD Preservers (CDI4) are designed to hold photo CDs with their contact sheets in a standard 3-ring binder or album.

**B. Place optical disks in individual Tyvek® sleeves (CDS44).**

These inert, non-abrasive, anti-static Tyvek® CD holders are also mold and tear resistant. Polypropylene CD Sleeves (CDS2) have a soft, black non-woven polypropylene interior and can hold two CDs.

**C. Never write on optical disks or stick labels on the surface.**

Instead use foil-back labels to identify sleeve contents. (ML1400F)

**D. Optical disks may also be stored in translucent, polypropylene cases.** Insert literature or labels inside case for quick identification. (CD56)

**E. Always store optical disks vertically.** Place sleeved or cased disks in boxes to protect them from dust and dirt. Use either a flip-top (CDB554) or a shallow lid (CDSB5125) for easy access. A CD Portfolio Box (CD80) has a handsome black buckram exterior and will hold 100 CDs in sleeves or 80 CDs in matching CD Bins (CD10BIN).



CD Cases



Flip-Top CD Box



Shallow Lid CD Box



CD Portfolio Box



CD Bins

**Please Note:** Product number references in text and photos along outside column all represent Gaylord product groups. Additional sizes, colors, etc. may be available. Please go to [Gaylord.com](http://Gaylord.com) and use product number or keyword description to find full selection.

## SECTION

## 3

## Archival Storage of Textiles

### Introduction 36

### Selecting Storage Materials

Paper Based 36

Cloth 37

Synthetic Materials 37

### Preparing Collections 38

### Selecting Storage Furniture 39

### The Storage Environment 39

### Case Studies

I: Small Flat Textiles 40

II: Large Flat Textiles 41

III: Garments 43

IV: Costume Accessories 44

## Introduction

The term “textile” covers a wide range of objects made of fiber—historic dress, flags, samplers, quilts and tapestries—as well as costume accessories such as handkerchiefs, hats and gloves. Due to their utilitarian nature, most textiles survive by chance. Some are cherished and carefully packed away, while others are displayed. Many, however, are used daily, washed frequently, and eventually discarded. Today we treasure historic textiles because they document art, craftsmanship, and have a very immediate connection with people of the past. We also save contemporary textiles for their beauty or their significance in our lives.

Unfortunately, textiles are among the most fragile of all artifacts. They are easily damaged by insects, mold, handling, and exposure to light, heat, and humidity. As with all art and artifacts, preservation begins with proper storage, whether the textiles are family heirlooms or part of collections in museums, historical societies or archives.

The goal of this section is to provide the background information needed to select appropriate storage materials for textiles. If your collections are small and in good condition, this may be all the information you need. However, if you would like to know more about textiles and their preservation, Section 5 will guide you to further readings. If your collections are extensive, in poor condition, or have significant value, it would be advisable to consult a textile conservator. The American Institute for Conservation (202-452-9545 or [www.conservation-us.org](http://www.conservation-us.org)) provides a free referral service that will give you the names of textile conservators in your region.

This section reflects our current understanding of storage requirements for textiles. It will be revised as new information and products become available. Unless noted otherwise, all of the items illustrated in this section are available from Gaylord. Call 1-800-448-6160 for a free Archival Catalog or visit [Gaylord.com](http://Gaylord.com).

## Selecting Materials

Before selecting storage materials, you should evaluate your collection for the types of fabrics, the sizes of the textiles and their condition. It is also important to assess the storage space that you have available. Although flat storage is ideal for some textiles because it minimizes damaging folds, space constraints may limit the size of the boxes or storage systems that you select. For guidance on storage of a large or valuable collection, consult a textile conservator.

Many materials used for household storage will damage textiles, including regular tissue paper, cardboard and wood. These materials are acidic and will hasten the deterioration of fabric, especially in historic textiles. Paper-based storage materials for your collection should be acid-free; other materials should be inert and have good aging properties.

**Paper-based Products:** Acid-free materials are either buffered (they contain a reserve of alkaline material) or unbuffered. Buffered papers and boards should be in contact only with textiles made of plant-based fibers, such as undyed cotton or linen. All other textiles and their dyes may be damaged by this

contact and should be stored using unbuffered materials. If you are unsure of the fabric, or if there are mixed fibers and/or blends, choose unbuffered materials. In uncontrolled environments, paper and cardboard can also help to buffer changes in relative humidity.

**Acid-free Tissue:** Gaylord acid-free tissue (UT30405) is a lightweight (.001 mil thick) paper that can be used to wrap textiles or pad three-dimensional forms. Buffered tissue (BT30405) has more body because it contains calcium carbonate, which is added as a buffer to give it a pH of 8.5. Abaca (A7-1162) is an unbuffered tissue that is particularly soft and suitable for interleaving fragile silks or padding. Choose tissue according to the qualities suitable for your textiles (body vs. softness, surface texture) and the type of fabrics you will be storing.

**Box Board:** Acid-free boxes are recommended for storage of some textiles. Board can be solid (TB30186) (made of the same material throughout); laminated (LFB20163) (sheets of heavy pressed fiber adhered together); or corrugated (EFNB19252) (one or more sheets of fluted paper glued between sheets of flat paper). Metal corners are used to reinforce solid board boxes; corrugated board is dimensionally stable and does not require this reinforcement.

Acid-free board can also be either buffered or unbuffered. Always line a box, whatever its material, with acid-free tissue before placing a textile inside.

**Cloth:** Undyed cotton fabric can be used in place of paper products. The fabric should be washed in a neutral detergent (OWAPD) (not soap), then run through another cycle without detergent and dried. Cotton muslin (400U5) is unsized and tightly woven, which makes it suitable for interleaving, outer wrappings, garment bags or coverings for padded hangers. Do not use muslin in contact with very fragile silks or other textiles that are easily abraded.

**Synthetic Materials:** Synthetic materials should be used with care for textile storage. Some of these materials are inert and may be used safely, but others will cause damage to the textiles. Wrapping or containing textiles in any plastic film or container can cause moisture condensation and promote mold growth, and is not recommended. Dry cleaners' bags are particularly unsuitable for storage of textiles because they cause yellowing and damage to textiles.

Some materials can be safely used for padding or lining boxes. Polyethylene foam such as Volara® (VOL-18) provides excellent drawer padding or box lining for accessories. Tyvek® (TR3050) is a spun-bonded olefin that is inert, pH neutral, non-abrasive and durable. It can be used to make garment bags or furniture covers. Polyester fiber batting (POLYBAT) can be used for padding; always use either needle-punched or heat-set batting, never resin-set. Always cover batting with muslin to prevent the textile from attracting polyester fibers.

Other synthetic materials can be used to seal unsuitable storage materials, such as wood, preventing off gassing of acids and other volatile compounds. Marvelseal® (M3610) and Melinex® (MR1200) are often used for this purpose. Isolate textiles from these materials with acid-free tissue to protect them from sharp edges, static and soiling.



Acid-Free Tissue



Textile Box

Deep Lid  
Multi-Purpose Box

Cotton Muslin



Volara



Marvelseal®

**Please Note:** Product number references in text and photos along outside column all represent Gaylord product groups. Additional sizes, colors, etc. may be available. Please go to [Gaylord.com](http://Gaylord.com) and use product number or keyword description to find full selection.

## Preparing Collections

Because textile collections are so varied in size and scope, and individual items can be extremely fragile, it is important to follow strict guidelines when preparing your collection for storage.

**Handling:** When handling your collection, plan your actions so as to minimize movement of the textiles. Any flexing or strain causes damage to textiles, although it may not be immediately discernible. See pages 85–90 in *Conservation Concerns* (Section 5, page 59) for an excellent discussion on condition of textiles.

Textiles easily pick up soil and oils, so be sure hands and all surfaces are scrupulously clean. Cotton or latex gloves can be worn when handling textiles, but be sure to take them off when performing other activities to avoid picking up dirt. Replace gloves when they become soiled. Do not smoke, eat, drink, or use pens and markers near textiles. Remove jewelry and watches that might snag textiles.

Be sure your work surface is large enough to fully support your textiles. Place all textiles on acid-free tissue (UT30405) on the work surface, and use the tissue to rotate or move the textile. Support textiles on acid-free cardboard (CB1620) when moving them from one place to another. Larger, rolled textiles can be moved on their tubes.

**Cleaning:** Most textiles can be safely surface cleaned by vacuuming; do this before storing textiles and after removing them from display. For all but the most robust rugs or tapestries, vacuum the textile at low suction through an upholstery screen (US1212). If your vacuum does not have adjustable suction, use your fingers to keep the nozzle elevated slightly to reduce suction.

For wet or dry cleaning of historic or valuable textiles, consult a textile conservator. Cleaning is a delicate process that can cause substantial damage and should be performed by an experienced and trained conservator.

Modern christening gowns and other new textiles of cotton, linen, or synthetic blends in good condition may be carefully hand washed. Use a pure detergent (OWAPD) (not soap, which causes yellowing) and distilled water. Modern wedding gowns or christening gowns should be cleaned immediately after wearing because soil and stains become more difficult to remove as they age. Most wedding gowns will require dry cleaning. Use a reputable dry cleaner and request fresh or filtered solvent.

**Repair:** If your textile or garment is new, a skilled seamstress may be able to make the required repairs. Historic or valuable textiles, however, should be examined by a conservator who has the experience and expertise to evaluate condition and recommend appropriate treatment. The American Institution for Conservation (202-452-9545) offers a free referral service and will give you the names of textile conservators in your region.

**Labeling:** Identification information should be placed on the storage container so textiles are not unwrapped and handled needlessly. Boxes, tubes, or other supports can be labeled in pencil. Avoid the use of pens or markers around any textile. Sew-on tapes made of cotton twill (L3872) can generally be used safely. Consult a textile conservator when establishing labeling procedures for an historic or valuable textile collection.

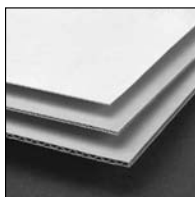

Acid-Free  
Corrugated Board



Orvus WA Paste



Upholstery Screen



Cloth Labeling Tape



## Selecting Storage Furniture

Before planning a storage installation, it is advisable to consult a textile conservator about configuration and materials. The size and type of furniture needed is determined by the type and number of textiles to be stored. Powder-coated steel storage cabinets are currently considered the best choice for textile storage. Wood and wood products, including cedar chests, are unsuitable for textile storage because they create an acidic environment. See pages 23-28 in *Conservation Concerns* for more details about wood and other materials. The NEDCC *Preservation Manual* also has excellent information about the choice of storage furniture.

If wood or otherwise unsuitable cabinetry must be used, it must be completely sealed on all interior surfaces with an appropriate barrier material (M3610/MR1200) or coating.



Visible Light Meter



Pest Monitoring Kit



Clothes Moth Trap Kit

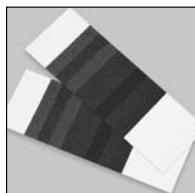

Textile Fading Cards

## The Storage Environment

While a textile is in storage it should be protected from damage caused by exposure to light, dust, fluctuating or extreme temperatures and humidity, harmful storage materials, mold, insects and animal pests.

**Temperature & Relative Humidity:** Textiles should be stored in an environment that is consistently cool and has a moderate humidity. Attics and basements are not suitable locations for storage of textiles because of their extremes of temperature and humidity. High temperatures speed deterioration and high humidity encourages insect and mold activity. Conversely, a low relative humidity contributes to the desiccation and embrittlement of fibers.

Cold storage is beneficial for textiles because deterioration is slowed and insects are less active. However, many storage areas have other uses and the climate also has to accommodate human comfort levels. The ideal climate is generally considered to be 65-70° F and 50% relative humidity with minimal fluctuations in both. For more detailed recommendations, see the publications on pages 59 and 60.

If necessary, portable humidifiers or dehumidifiers can help maintain a stable RH so long as they are kept clean and are routinely monitored. This equipment must run 24 hours a day.

**Light:** Light is particularly damaging to textiles because it causes fading of dyes and deterioration of fibers. Its effects are cumulative and irreversible. Textiles should not be exposed to light while they are in storage; protect them with blackout covers or by storage in boxes or closed cabinets. When exposure to light is necessary for examination or display, filter all light sources to remove ultraviolet wavelengths and keep illumination levels as low as possible.

Recommendations for the exhibition and display of textiles are outside the scope of this section, but several of the publications listed on pages 59–60 contain suggestions for minimizing the risk of exhibition.

**Pest Management:** There are two main types of insect pests, which can damage textiles: clothes moths (webbing or casemaking), and dermestids (carpet beetles). Wool is the preferred food for both of these pests, although they will eat other materials if they are soiled or to get to an attractive material. These insects prefer a warm, humid and dark environment. The best way to prevent infestation is to provide an inhospitable environment: keep textiles in a cool, dry location. Light exposure and air circulation resulting from periodic inspection will also discourage insects.

**Please Note:** Product number references in text and photos along outside column all represent Gaylord product groups. Additional sizes, colors, etc. may be available. Please go to [Gaylord.com](http://Gaylord.com) and use product number or keyword description to find full selection.



Shallow Lid  
Textile Boxes



Textile Boxes—  
Drop-Front, Deep Lid



Acid-Free Tissue

Vacuum your textiles before putting them in storage to remove particulate soil that can attract insects (see “Cleaning” on page 38). Do not use mothballs, moth flakes or other chemicals to prevent infestation; they are hazardous to your health and can harm your textiles. Cedar chests and herbal preventatives are generally ineffective.

Monitor your storage area for insect activity by placing sticky traps (25020) in strategic locations. Several of the references on pages 59–60 have more information on pest monitoring. If you find evidence of insect activity in your traps or in your collection, isolate any affected textiles in a polyethylene bag and consult a textile conservator.

Rodents can also damage textiles; they don’t eat the fabrics, but will shred them to make nests. Protect your collection by storing it securely in boxes or cabinets, and monitor rodent activity with appropriate sticky traps.

## Case Studies

Selecting specific interleaving paper, boxes, cloth, and storage systems requires care. Physical condition, size of collection, anticipated use, and budget all play a part. The second half of this section presents several case studies to show how products available from Gaylord can be used to store a range of textiles.

### CASE STUDY I: SMALL FLAT TEXTILES

Flat storage for small flat textiles such as embroideries and handkerchiefs is ideal because it places no strain on the object. Whenever possible, select a box or drawer large enough to store the textile without folding.

#### A. Storing a single textile in a box

1. Choose the type and size of box (TB30186) that best fits your textile.
2. Select an appropriate lining material:
  - Buffered tissue (BT30405) for undyed cellulosic fibers
  - Unbuffered tissue (UT30405) for silk, wool and all dyed textiles, or mixed or unknown fibers
  - Washed cotton sheeting (400U5)
3. Lay the lining across the bottom and sides of the box. Place the textile in the box.
4. Fold the lining over the textile. Label the box.

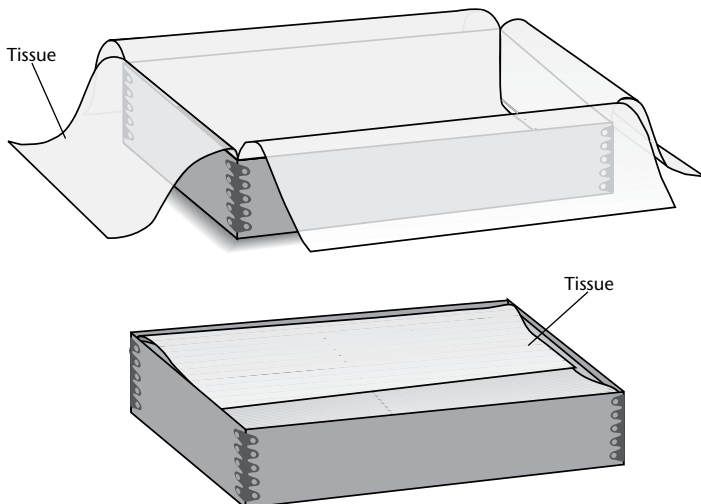

## B. Storing more than one textile in a box.

If space constraints make it impossible to store only one textile in a box, follow steps A1–3 above, placing the heaviest item on the bottom. Place acid-free tissue between each item and fold the lining material over the top textile.

## C. Storing fragile textiles

Small, very fragile textiles such as archaeological fragments should be protected by a special storage mount. This mount consists of a piece of acid-free board (RNBW41114) covered with polyester felt and washed cotton fabric, with a window mat hinged to one side of the support board. The mat should be larger than the textile and made of material that is thicker than the textile. The textile is placed on a piece of acid-free tissue on the mount, and covered with another piece of tissue before the mat is closed. These mounts can be stacked inside a box or drawer.

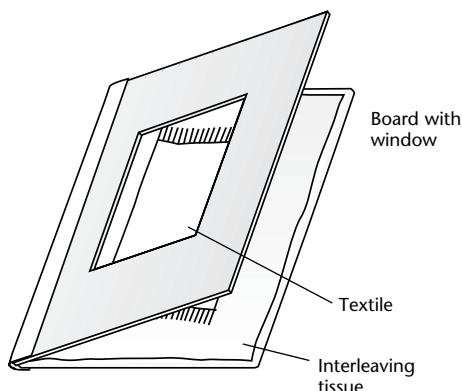

Deep Lid  
Multi-Purpose Box



Roll Storage Tubes



Cotton Tying Tape

## CASE STUDY II: LARGE FLAT TEXTILES

Rolled storage is generally the best method for large flat textiles such as quilts, carpets, shawls, and table linens because it prevents creasing and provides complete support. Painted textiles such as flags should be stored flat whenever possible; they should never be stored folded in a box. Folded storage in a box or drawer may be necessary for some textiles because they are not flat enough to roll, or they have bulky surface decoration.

### A. Rolled storage

1. *Select an archival quality storage tube (52232) that has a diameter of at least 3", or larger for heavier textiles such as rugs. The tube should be 6–8" longer than the width of the textile.*
2. *Cover the tube with acid-free tissue (UT30405), tucking the ends into the ends of the tube. Cut another piece of tissue slightly shorter than the length of the tube, and roll this onto the tube leaving the last 6–8" free.*
3. *Most textiles should be rolled in the warp direction, and rugs or other pile textiles must be rolled with the nap. See page 41 in *Preserving Textiles* for a drawing that illustrates this. Place one end of the textile on the loose acid-free tissue; make sure the textile is straight and free of creases. In most cases it is best to place the textile face-down so that the obverse of the textile is on the outside of the roll.*
4. *Begin rolling the tube, picking up the end of the textile with the tissue. Be sure that the textile rolls without creases, and that it is as straight as possible. In most cases it is not advisable to interleave with tissue as you roll, but do this for fragmented textiles or those*

**Please Note:** Product number references in text and photos along outside column all represent Gaylord product groups. Additional sizes, colors, etc. may be available. Please go to [Gaylord.com](http://Gaylord.com) and use product number or keyword description to find full selection.



Pigma Pens



Polyester Batting



Stockinette Tubing

with sharp surface decoration. A textile that has a lining will be difficult to roll smoothly; avoid creasing the textile itself, but creases in the lining are inevitable.

5. *Cover the rolled textile with acid-free tissue or washed muslin (400U5) and tie cotton twill tape (02100) around the covering beyond the ends of the textile. For larger textiles, loosely tie twill tape around the middle of the tube, being careful not to compress the textile.*
6. *To label the rolled textile, write the accession number on the tube with pencil, write the accession number on the cotton twill tape ties with a permanent marking pen (XSDK08-49), and sew a piece of tape with identification information onto the muslin. If several textiles are unrolled for study, it will be easy to match them with the correct storage materials.*
7. *If possible, suspend the tube on brackets or a dowel. This will eliminate the pressure on the textile caused by storing the tube on a shelf.*

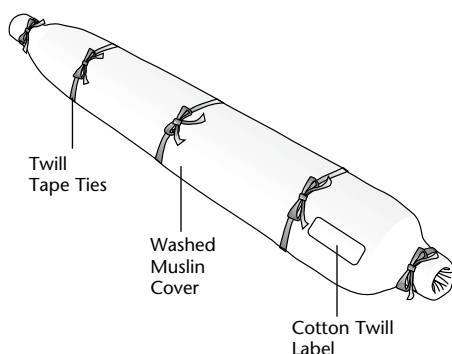

## B. Boxes

1. *Select a box (TB30186KD) that is large enough to minimize folds for your textile.*
2. *Select an appropriate lining material—acid-free tissue or washed cotton sheeting—and line the box with this material.*
3. *Place the textile on a clean flat surface and fold it to fit the box, using as few folds as possible. Pad all folds with rolled acid-free tissue or tubes of polyester batting (POLYBAT) covered with washed muslin (400U5) or stockinette (34587).*
4. *Place the textile in the box, fold the lining material over the top of the textile and close the box.*
5. *Label the box with information about the textiles stored inside of it.*

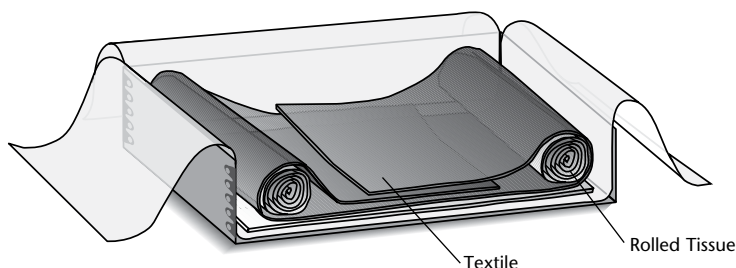

## CASE STUDY III: GARMENTS

Garments present challenges for storage because they are three-dimensional. Storage in boxes or drawers avoids the strain of hanging storage, but results in creasing of the garment. In general, if a costume is suitable for hanging this is the preferred method. Costumes that are unsuitable include those in poor condition, those with heavy beading or other decoration, garments cut on the bias, and any garment that is weak or insubstantial in the shoulder area. The publications listed on page 59–60 will give you more detailed information. However, we recommend that you consult a textile conservator before storing a collection of valuable, historic costumes.

### A. Hangers

Costumes that are hung for storage should always be on padded hangers. A hanger with a wide shoulder (10015) can be covered with polyester felt or batting (POLYBAT) and then with washed cotton fabric or stockinette (34587). Additional support can be added in the form of twill tapes stitched into waistbands or other strategic locations and then tied to the neck of the hanger. Some skirts and pants can be stored hanging using commercial skirt hangers padded with muslin-covered batting. Garments can be further protected from dust and light by covering with a cotton muslin (FCSDC) or Tyvek® (TR3050) garment bag. Do not crowd hanging garments, as this can cause creasing.

More information on hanging storage and directions for making padded hangers and garment bags can be found in *Preserving Textiles, Caring for Your Collections* and *CCI Note 13/5 "Hanging Storage for Costumes."*

### B. Boxes

1. *Large costume storage boxes (CB84018) come in a variety of sizes. If possible, select a box that is longer than your garment.*
2. *Line the box with acid-free tissue (UT30405) or washed cotton fabric.*
3. *With the garment on a flat surface, arrange the various parts, such as sleeves, in a natural position. Skirts should be arranged with vertical folds placed so that the fabric is not strained. Try to make as few folds as possible to make the garment fit the box. If the garment is longer than the box it will be necessary to fold it crosswise to fit. Position this fold in a location that will cause the least strain on the fabric. Using acid-free tissue or tubes of polyester batting covered with washed cotton fabric or stockinette, pad all of the folds in the garment. In most cases sleeves should not be padded, as it can be damaging to insert and remove the padding.*
4. *Gently lay the textile in the box and fold the lining over the top. If possible, avoid stacking garments in a box to minimize creasing.*

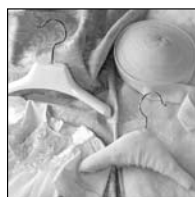
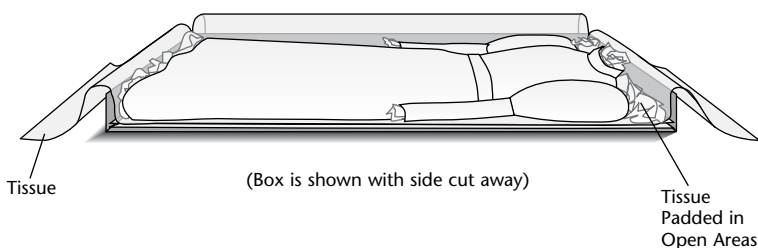

Hangers—Polystyrene



Garment Dust Covers



Deep Lid  
Costume Boxes

**Please Note:** Product number references in text and photos along outside column all represent Gaylord product groups. Additional sizes, colors, etc. may be available. Please go to [Gaylord.com](http://Gaylord.com) and use product number or keyword description to find full selection.



Interior Trays  
with Dividers



Shoe  
Preservation Kit



Hat &  
Artifact Boxes



Acid-Free Tissue

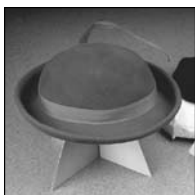

Hat Mount Stand

## CASE STUDY IV: COSTUME ACCESSORIES

Costume accessories can be composites of various materials, including plastics, so it is best to select an unbuffered tissue (UT30405) to isolate and wrap individual items. The boxes may be buffered or unbuffered, but should always be lined with acid-free tissue or washed cotton fabric (400U5).

### A. Fans

Unless a collection is in constant use, most fans should be wrapped in acid-free tissue (UT30405) and stored in partitioned archival boxes (SCTD6/ARTLID). Consult a textile conservator if the fan is fragile or has painted decoration.

### B. Gloves

Store gloves flat in archival boxes (CF1253), interleaved with acid-free tissue (UT30405).

### C. Shoes

Shoes can be stored in archival boxes (CL1264KT), on shelves or in drawers. Pad them with archival tissue for support. Delicate or fragile shoes should have a padding designed by a textile conservator. Store shoes upright; taller shoes and boots can be stored on their sides. If a shoe has ribbons or flaps that are unsupported, they can be secured with loose twill tape ties (02100).



### D. Hats

Hats can be stored in archival boxes (HB121313) or in cabinets. The hat should be supported so that it does not rest on its brim and the weight of the hat is not borne by the crown; there are several possible methods of providing support. The hat can be padded with acid-free tissue (UT30405), or a support can be made from acid-free corrugated board (EFCB810) or some other archival material, padded with polyester batting (POLYBAT) and covered with acid-free tissue. In general, cotton fabric is not suitable for padding or wrapping historic hats.

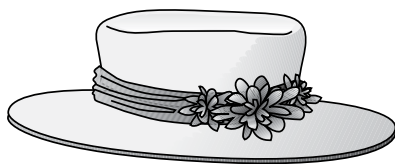

Tissue  
Support

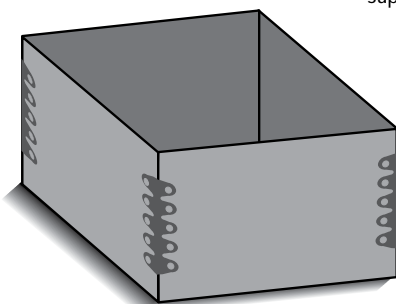

## E. Handbags

Handbags can be constructed of cloth, tapestry or other fabric. They can also be a combination of leather and fabric. Many handbags are made of synthetic materials—from bakelite to vinyl—or other natural materials such as straw, wicker, or tortoise shell. Loosely stuff the handbag with acid-free tissue (UT30405) to retain its shape. If the handbag has exterior decorations, such as shells, beads, or sequins, it should be gently wrapped in acid-free tissue to prevent any snagging or accidental loss. An individual archival box (T3512) or an archival storage carton (RC121510) with trays and compartments (AT755) for individual bags is recommended. Be sure to line the compartment with acid-free tissue.

## F. Jewelry

While jewelry is technically not a fabric or textile, it often accompanies a costume and is therefore appropriate to discuss here. Jewelry can be placed in small artifact boxes (CL221/AB221) or in divided trays or cartons (AT232). Wrap each piece individually in acid-free tissue or, to be able to see the piece without handling it, you may also use padding covered with acid-free tissue to create a well for the object. Do not place jewelry in loose batting that can get caught in the prongs or tangled between the gemstones and settings. Silver jewelry can be stored in a pouch made of Pacific Silvercloth (PC3815) to prevent tarnishing.



Cartons & Trays—  
4 Compartment



Cartons & Trays—  
15 Compartment



Curator Modular  
Box System



Clear Artifact Boxes



Deep Lid  
Artifact Boxes



Pacific Silvercloth

**Please Note:** Product number references in text and photos along outside column all represent Gaylord product groups. Additional sizes, colors, etc. may be available. Please go to [Gaylord.com](http://Gaylord.com) and use product number or keyword description to find full selection.

# SECTION 4

## An Introduction to Book Repair

<b>Introduction</b>	<b>46</b>
<b>Defining Book Repair</b>	
Parts of a Book	<b>46</b>
Types of Book Damage	<b>47</b>
Selecting a Candidate for Repair	<b>48</b>
<b>Setting up a Workspace</b>	<b>49</b>
<b>Selecting Tools, Equipment &amp; Supplies</b>	
Small Tools	<b>50</b>
Larger Equipment	<b>52</b>
Supplies	<b>53</b>

## Introduction

Books are meant to be handled, but their very use causes damage from wear and tear. Poor storage conditions and acidic paper also contribute to their deterioration. Even new publications printed on acid-free paper fall apart because of poor quality adhesive bindings. Misguided repair has also damaged books. Stiff repair tapes, yellowed cellophane tapes, over-trimming and poor rebinding have all destroyed original paper and bindings. For libraries, shrinking budgets for replacement and increasing demands for access brought on by use of online catalogs only compound the problem. Fortunately, alternatives now exist.

The goal of this section is to provide background information for those about to begin or improve the repair of their book collections. Although it is oriented toward librarians setting up basic repair programs, others will also find it useful. Collectors and private individuals need the same basic tools, supplies, equipment, and manuals—even if working on a small scale.

The treatment of rare books, leather bindings, and special collections material is outside the scope of this section. It is advisable to consult a professional bookbinder or book conservator if your collections include these materials. Section 5 provides contact information for the Guild of Book Workers, whose Membership Directory lists bookbinders by geographic regions, and the American Institute for Conservation, which provides a free referral service to conservators in your area. See Section 1, Case Study VII, for information on proper storage and handling of rare books and bound materials.

The information in this section reflects our current knowledge regarding the set up of a book repair program. It will be revised as new information and products become available. Unless otherwise noted, all of the items illustrated in this section are available from Gaylord. Call 1-800-448-6160 for a free catalog or visit us online at Gaylord.com.

## Defining Book Repair

Book repair is remedial. It corrects damage that has occurred because of poor manufacture, use, abuse, and/or aging. For the purposes of this publication, we are restricting its definition to the repair of bindings and textblocks of modern books in general collections. These are typically case bindings with covers made of cloth or paper over boards.

### PARTS OF A BOOK

A typical case bound book has two components:

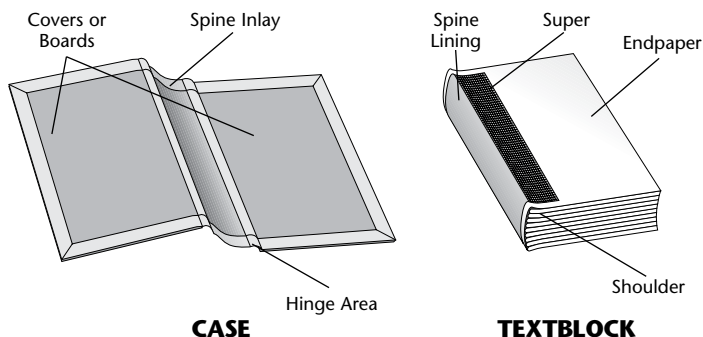



- *The Case*, made up of front and back boards (covers) and a stiff spine liner (spine inlay), covered by cloth or sturdy paper.
- *The Textblock (contents)*, made up of pages sewn or glued together. A folded sheet of paper (endpaper) is glued to the shoulder of the first and last page of the textblock. The spine is lined with an open weave cloth (super) that extends onto the endpapers. The spine is strengthened further with a paper lining. The textblock is attached to the case by gluing the endpaper and super to the boards. The spine inlay is not glued to the spine lining of the textblock. This creates a hollow that allows the binding to flex and open easily. The hinge area (called the joint on the outside of the case) takes most of the strain of use and is typically the first area to show signs of damage.

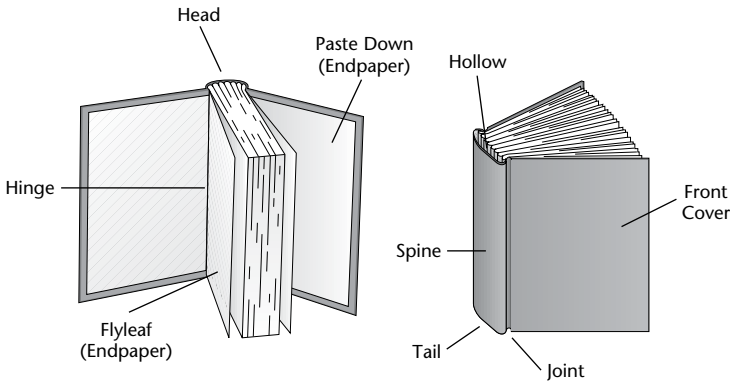

## TYPES OF BOOK DAMAGE

Damage occurs most often in three areas: the textblock (torn or soiled pages, detached pages, missing pages), the case (warped, soiled or abraded covers; torn headcaps, detached spines), and the attachment of textblock to the case (loose hinges, broken hinges, detached covers). One book can have several types of damage.

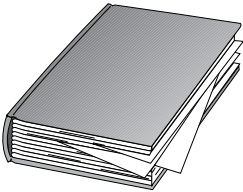

Detached Pages

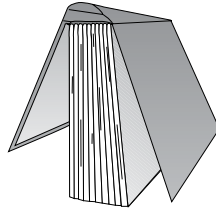

Loose Hinges

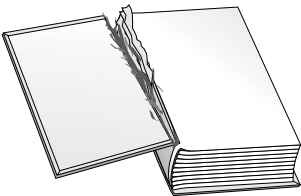

Torn Cover

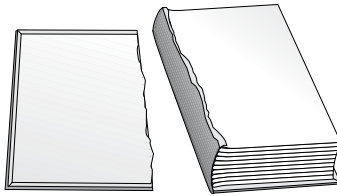

Detached Cover

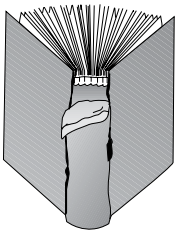

Detached Spine

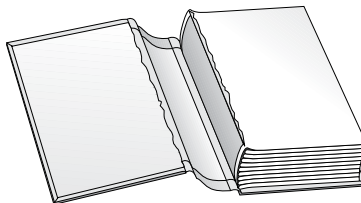

Detached Case

**Please Note:** Product number references in text and photos along outside column all represent Gaylord product groups. Additional sizes, colors, etc. may be available. Please go to [Gaylord.com](http://Gaylord.com) and use product number or keyword description to find full selection.

## SELECTING CANDIDATES FOR REPAIR

Book repair should be an integral part of library operations. To make decision-making as efficient as possible, establish routines for sorting and evaluating damaged books. The following are general guidelines. Each library will set its own criteria and assign staffing responsibilities. Collectors will also benefit from seeing the scope—and limitations—of book repair. Many of the general principles outlined below apply when selecting books for purchase or for repair.

**Catch damage early.** Work with staff to identify volumes with minor damage such as loose pages or loose hinges before they become major problems. It takes less time and money to do a minor repair than a more extensive repair. Encourage patrons to note damage when an item is returned rather than do it themselves. “Home-made” repairs are usually damaging and difficult to reverse.

### Sort damaged books into categories:

- Books to be repaired—Volumes with torn or loose pages, worn spines and covers, loose hinges, detached covers, or other minor damage. The paper should be flexible and not brittle.
- Books to be rebound by the library binder—Volumes with a larger number of detached pages, badly damaged covers, and major damage that cannot be repaired in the library. The selection of books for rebinding depends upon local factors such as budget and the importance of the book to the collection. Only books with flexible paper can be rebound.
- Books to be replaced or reformatted—Volumes that are brittle, yellowed, or have extensive losses. Depending upon library policy and availability, these may be replaced with a new copy, reprint, microfilm, or preservation photocopy.
- Books to be discarded—Volumes that do not warrant the time or expense to repair or rebind. These may include books with missing pages, out-of-date information, or lack of relevance to the collection.
- Books to be reviewed for conservation or boxing—If a volume has historic, monetary, or artifactual value, set it aside for treatment by a conservator or hand bookbinder. Some libraries have established a date cut-off—1900 for example—for review by a bibliographer before treatment. It is better to box or wrap a valuable volume than treat it incorrectly. See Section 1, Case Study VII, for further information on storage of rare books and bound materials.

**Batch candidates for repair.** Once the damaged books have been identified, sort them into the categories of repair.

**Select repair materials that are chemically stable and non-damaging.** Avoid materials such as acidic papers and book repair tapes. For examples of acceptable materials, see the Supplies on page 53.

**Use techniques that are structurally sound.** Consult the manuals on page 60 and obtain training to execute repairs that will contribute to the long-term stability and preservation of your collection.

**Work systematically.** Most manuals recommend working on 5–10 volumes at a time for maximum efficiency. Precutting supplies will expedite this process. Examine the textblock and do any paper mends before proceeding to the binding.

**Maintain quality control.** Work should be neat, accurate, and sound. Book repair is no place for sloppy craftsmanship. When new staff are assigned to repair, they should be trained by an experienced person and given manuals for reference. Their work should be reviewed periodically to be certain they understand both principles and techniques of book repair.

## SETTING UP A WORKSPACE

If you anticipate doing repair on a regular basis, set aside a designated area with ample space for both work and storage. This space should provide access to a sink, adequate ventilation, and good lighting. Before investing in large equipment such as a cutter or presses, you should have a clear idea of the type of work that you will be doing, both now and in the future. Visit other workshops that have comparable programs.

### Workbench or Tables

Each person should have a workbench (711836) equivalent to the size of a large desk (2<sup>1</sup>/<sub>2</sub> x 6 ft.). The best height is between 36 and 40 inches so that the person can work comfortably while standing. Low-cost alternatives are a work table raised on wooden blocks, provided the table is sturdy and stable. The work surface should be easy to clean; formica or a wood surface treated with polyurethane are good choices. It is convenient to have a set of shelves beneath the bench to hold paper and other materials.

### Stools or Chairs

Stools or chairs should be available for each worker. They should be 6-12" lower than the bench. Wooden stools are the least expensive alternative, but you may want to purchase a cushioned chair with back support if the person is to work for long periods of time.

### Lighting

Good lighting is essential for doing book repair. A high intensity lamp provides task lighting to supplement overhead lighting. Be sure to purchase a model that uses a minimum of 100 watts to give strong lighting.

### Storage

You will need storage for repair materials and supplies. Itemize the amounts and sizes of paper, board, and cloth that you will be using and plan accordingly. Open metal shelving (RAS42153) is an inexpensive alternative, but you may want to use flat files (map cases) (4994-01/7867-01) to protect sheets of Japanese paper or endpaper stock. Peg boards, jars, shelves, containers can all be used to keep tools close at hand. The manuals by Greenfield and Lavender (page 60) contain good illustrations of workbenches and storage units.



Media Work Station  
Processing Cart



Wire Shelving



Flat Files

**Please Note:** Product number references in text and photos along outside column all represent Gaylord product groups. Additional sizes, colors, etc. may be available. Please go to [Gaylord.com](http://Gaylord.com) and use product number or keyword description to find full selection.

## Selecting Tools, Equipment & Supplies

### SMALL TOOLS

The following tools are recommended for general use in book repair. You may need additional tools for specialized treatments. You will find these listed in the manuals that describe the treatments.

**Awl (AWL):** small, sharp tool; used for making holes when sewing in pamphlet bindings or preparing endpapers and signatures for sewing.

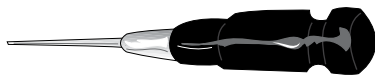

**Bone Folders (6480/6481):** smooth, flat tool with rounded or pointed ends; used to crease paper, to rub down paper and cloth after gluing, and to set the joints when repairing bindings.

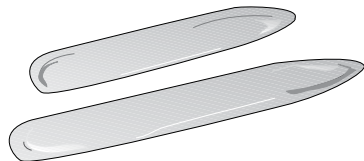

#### Brushes:

- *Glue brushes (895B-14)*—round bristle glue brushes for applying adhesive to broad areas.
- *Small artist's brushes (PP1)*—for mending paper and hinging, applying adhesive in small places
- *Dusting brush (BR364)*—to clean off work surfaces



**Containers:** sturdy plastic containers in a range of sizes to hold tools and water, with lids to hold small quantities of adhesives.

#### Cutting Tools:

- *Scalpel (30975), mat knife or other cutting implements*—for trimming paper or cutting materials. Have extra blades on hand. A dull cutting tool can be dangerous and difficult to use.
- *Utility knife (HM23)*—useful for cleaning the backs of spines.
- *Self-healing Cutting Mat (52051)*—provides a grid surface for cutting paper; particularly useful when trimming endpapers on the book where you cannot use a paper cutter. Does not dull the blades of cutting implements.

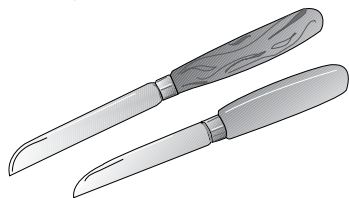
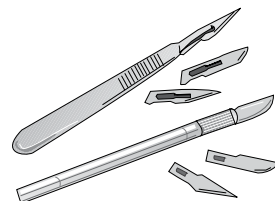

**Hammer:** a special bookbinder's hammer, used with a backing press (TCP) to shape the spines of the textblock prior to binding.

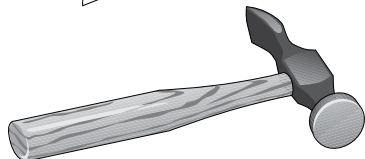

**Microspatula (MIC):** a useful tool for lifting tape and getting adhesive into narrow places.

**Needles (769/774):** large eyed needles (No. 3 darning needle or No. 6 crewel needles are useful sizes) for sewing pamphlets into binders and for sewing signatures.

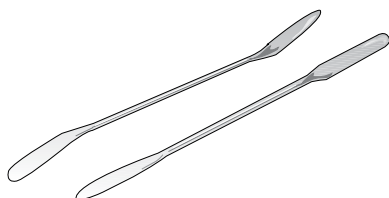

Awl

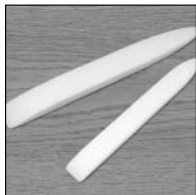

Bone Folders

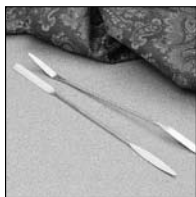

Round Glue Brushes

Cutting Mat,  
Scalpels & X-acto Knife

Microspatula

**Press Boards:** wooden boards are needed for pressing material under weight. These may be hardwood, plywood, or tempered masonite, sanded and finished with polyurethane. Useful sizes are 9 x 12" and 6 x 9".

- *Metal edged press boards* (BB912)—wooden boards with metal edges on the long side, projecting  $\frac{1}{16}$ ".
- *Plexiglas rods* (PG1812) or *No. 4 or 5 knitting needles*—for applying adhesive when tightening hinges or pressing hinges with boards (see page 52).

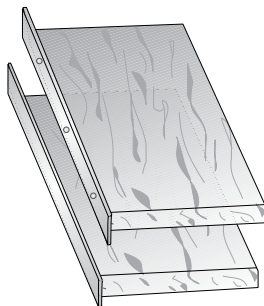

### Rulers and Straight Edges:

- *Rulers*—used for measuring.
- *Metal straight edges* (R59012A)—for cutting with scalpels or knives, and for scoring with a bone folder.
- *T-Squares and Triangles*—for cutting materials where right angles are required.

**Shears:** good quality, accurate shears and scissors in a range of sizes are essential.

- *Heavy shears* (9911) for cutting lightweight board and cloth.
- *Medium sized scissors* (D7778) for cutting paper.
- *Smaller scissors* (08535) for reaching narrow spaces.



**Tacking Iron** (57038): small, lightweight iron, thermostatically controlled; used to apply heat-set tissue or dry mends.

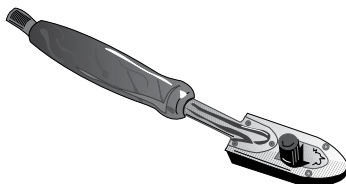

### Weights:

- *Bricks wrapped in heavy paper or binders cloth.*
- *Bean bags or leather/cloth weights* (05-110) filled with shot.
- *Jars filled with shot or pennies, paperweights.*
- *Plexiglas covered lead weights.* (WT442)

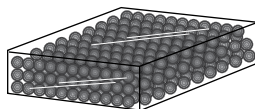
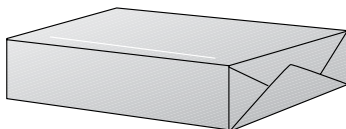

Brass-Edged Boards



Shears, Thread & Needles

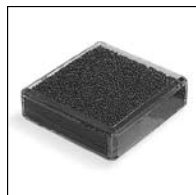

Weight—Lead Filled Acrylic



Book Repair Tool Kit

**Please Note:** Product number references in text and photos along outside column all represent Gaylord product groups. Additional sizes, colors, etc. may be available. Please go to [Gaylord.com](http://Gaylord.com) and use product number or keyword description to find full selection.

## LARGER EQUIPMENT

**Book Presses:** One of the guiding principles of book repair is to get good adhesion between the hinge of the textblock and the joint of the case. If budgets are limited, you may begin with boards, bricks, and knitting needles or Plexiglas rods. However, metal-edged boards (BB912) are a more efficient and effective way of setting the joints. They may be used with weights (WT08) or with book presses. The Gaylord press (712) is a low cost alternative. If you rebind large numbers of books, a heavy metal book press and press boards will improve the quality and efficiency of your work.



Book Repair Rods—  
Plexiglas®



Book Weights—  
Nickel-Plated Steel



Bookcraft Book Press

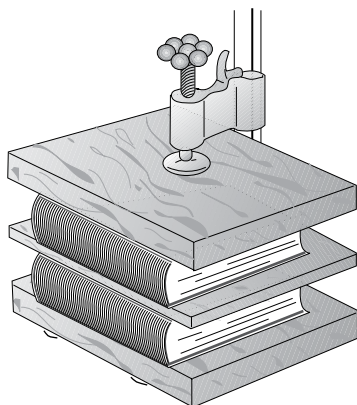
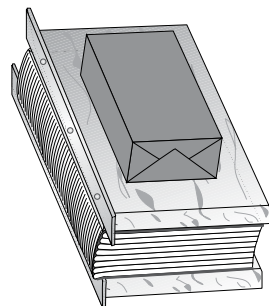
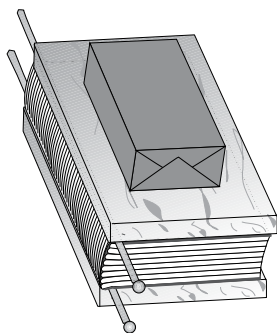
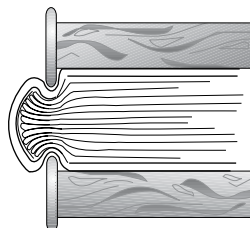
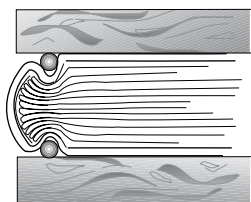

Gaylord Press

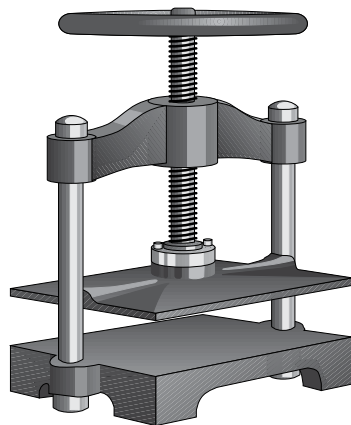

Metal Book Press

**Casing Press:** As repair operations expand, you may want to add Gaylord's casing press (TPCP). The press itself can be attached to the workbench and used as a book press to set the joints of bindings after repair. Assembled in its stand with beveled boards, it becomes a backing press, a versatile machine for holding the textblock when cleaning or backing/reshaping spines, or doing finish work.

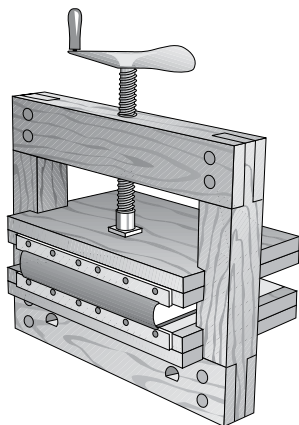

Casing Press

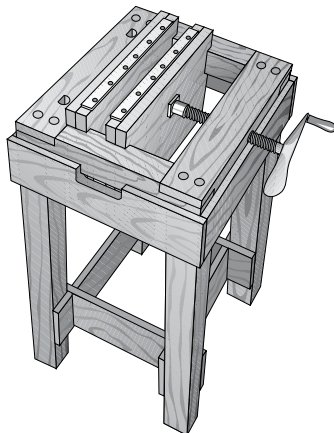

Casing Press &amp; Stand

**Board Shear or Heavy-duty Cutter:** A cutting mat (52056) and a sharp table model paper cutter (D12) will be adequate for simple mending and repair. However, if you want to do rebinding or make boxes—which requires frequent cutting of heavy board—you will need a heavy cutter. A board shear, or heavy-duty cutter, is a major financial investment and requires substantial space in the workshop. However, it is also one of your most important purchases because a sharp, accurate cutter will improve the quality and speed of work. It is important that the cutter be able to cut board and paper; that the blade be long enough to cut most common lengths of materials; that it have a clamping bar to hold materials being cut; and have scales for accurate measuring. Board shears are best for a professional bindery. Heavy-duty table models can cut light-weight board and are less expensive than floor models. Gaylord carries book presses and a heavy-duty table model cutter (52060). For vendors of board shears, large presses, and other heavy bookbinding equipment, consult the Supplies Directory of the Guild of Book Workers (Section 5, page 56). It is sometimes possible to find used equipment advertised in the Newsletter of the Guild of Book Workers.

## SUPPLIES

The choice of materials for repair is critical. They should be acid-free, chemically stable, and durable. Labor is the most expensive cost of repair so it is not cost effective to save money on supplies if it results in repairs that fall apart because of stiff, brittle adhesives or papers and tapes that turn yellow and stain. The following are the most common supplies used in basic book and paper repair. You may find more specialized supplies listed in manuals that describe specific treatments.

**Adhesives:** used to bond paper, board, cloth, and the book together during repair. Three types of adhesives are commonly used: starch paste and methyl cellulose for paper repair because of their reversibility, and PVA for binding repair because of its flexibility and strength.

- **Starch Paste**—Wheat starch makes a smooth, strong paste. It is made by cooking, though a pre-cooked wheat paste (52000) is also available. Both have a limited shelf life after preparation.
- **Methyl Cellulose**—Methyl cellulose (MC1A) is easily made by mixing powder with water. When paper repair is not done often, it is a good alternative to starch paste because it has a long shelf life.



Casing Press



Casing Press with Stand



Vantage Paper Trimmer



Heavy-Duty Board Cutter

**Please Note:** Product number references in text and photos along outside column all represent Gaylord product groups. Additional sizes, colors, etc. may be available. Please go to [Gaylord.com](http://Gaylord.com) and use product number or keyword description to find full selection.



White pH  
Neutral Adhesive



Folder Stock



Binder Board



Cambric Tape



Book Cloth

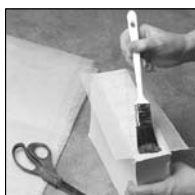

Super Cloth



Vinyl Eraser

- *PVA adhesive (A6464Q)*—Polyvinyl acetate is a white synthetic resin that dries to a thin, clear, flexible film. It is water-based and is used in bookbinding where reversibility is not important.

**Board:** Several kinds of board are used when doing book repair. Its thickness is measured in points, which correspond to mils or thousandths of an inch. For example, the blue/grey barrier board (BG1620) used for phase boxes is 60 points thick or .060 inches thick. Board should be acid-free. Be certain that your cutter can handle the size and thickness of the board that you choose.

- *Lightweight folder stock*—7-pt. folder stock (SS0810) is used for spine inlays and map pockets in the backs of books.
- *Folder stock*—10-pt. (LTF3240) and 20-pt. (HDF1620) folder stock makes lightweight folders and enclosures, while 40-pt. stock is used for enclosures. 60-pt. stock can be used for the covers of pamphlet binders and phase boxes.
- *Binders board*—Gray Davey Board is the traditional board used by binders. An acid-free version is now available in thicknesses from .070 (263874A) for small books and .082 (263882A) for standard sized books to .098 (263898A) for large books.

### Cloth:

- *Cambric (WC4T)*—A closely woven white, starch-filled linen cloth used for hinges and spine linings.
- *Super (SPR01A)*—A loosely woven cloth used to line the backs of spines.
- *Bookcloth (CBR2-01)*—A generic term for the woven materials used to cover the case of books. It is typically made of cotton or poly-cotton with starch and pigment fillers and an acrylic surface coating. Gaylord carries five colors in convenient 2", 3", 4", 5" and 6" rolls for book repair. These cloths, along with a wide range of linens and fine paper-backed cloths, are available by the yard from vendors specializing in bookbinding supplies (see the Guild of Book Workers *Supply Directory*, page 56). The finer cloths are not appropriate for circulating library books because they become soiled easily.

### Erasers:

- *Vinyl erasers such as Magic Rub (73207) and Mars Staedtler (92511)* erasers are recommended because they leave less residue on the paper.
- *Document cleaning pads (A6462)* of powdered eraser are even gentler.

### Papers:

- *Endpaper stock (WT2335/BL2335A)*—Papers selected for endpapers should be acid-free, buffered, and durable. Several colors are desirable: white for modern books, cream or beige to match the texts of older books. If precut sheets are available, select a size that fits your cutter blade.
- *Japanese paper (JTPK)*—Traditional handmade Japanese papers are excellent for repair because their long fibers provide a strong, yet flexible join. They come in a range of shades and weights. Libraries typically use medium weight for guarding signatures and lightweight for mending paper.
- *Heat-set tissue (R12233)*—This fine paper is coated on one side with an acrylic adhesive that adheres when heat is applied with a tacking iron. Heat-set tissue is used for mending tears and consolidating shattered edges of paper, especially for moisture-sensitive paper that cannot withstand the application of a wet paste.

### Other papers are also needed for repair operations:

- *Blotting paper (UBP20301)*—for drying and flattening paper.
- *Silicone release paper (929A)*—for use with a tacking iron when applying heat-set tissue.



- Scrap paper—for all operations. Avoid fresh newsprint or any other paper with printing or writing that may offset onto your work.
- Wax paper—as a barrier prevents adhesive from sticking to adjacent surfaces while work dries. Gaylord makes a special wax paper (96) for book repair.

**Tape:**

Although the range of tapes has increased dramatically with the development of synthetic materials and more stable acrylic adhesives, it is best to consider all tapes to be permanent. Once applied, tape is difficult or impossible to remove. Filmoplast tapes are considered acceptable for some types of paper repair. Filmoplast P (TP) has a lightweight, acid-free paper carrier with a stable adhesive. However, even it should not be used on rare books, documents, or archival materials with artifactual value. Some research libraries use Japanese paper and starch paste for nearly all their paper mending, even on circulating collections. However, this requires a trained staff.

**Thread:** High quality linen thread should be used for sewing because of its strength. Medium weight is the most versatile, while heavier weight thread (LT183A) is used to sew pamphlets.



Document  
Cleaning Pad



Japanese Papers



Filmoplast R  
Heat Set Tissue



Waxed Paper

**Please Note:** Product number references in text and photos along outside column all represent Gaylord product groups. Additional sizes, colors, etc. may be available. Please go to [Gaylord.com](http://Gaylord.com) and use product number or keyword description to find full selection.

## SECTION

## Resources

As you seek to expand your knowledge of preservation and conservation, the following websites can provide reliable information, much of which can be downloaded. We have noted special services or publications when appropriate (such as the interactive guide *Find a Conservator* of AIC and study opportunities of GBW). We urge you to explore the sites and their links to other preservation resources, either on your own computer or at your local public library.

### **American Institute for Conservation of Art and Historic Artifacts (AIC)**

1717 K Street NW, Suite 200, Washington, DC 20006  
Phone 202-452-9545 • [www.conservation-us.org](http://www.conservation-us.org)

AIC is the national membership organization of conservation professionals dedicated to preserving the art and historic artifacts of our cultural heritage. Its site includes an interactive on-line guide *Find a Conservator*, which will allow you to identify a conservator in your region. Brochures on *Caring for Your Treasures*, *Guidelines for Selecting a Conservator*, and *Conservation Training in the United States* can be ordered or downloaded.

### **Canadian Conservation Institute (CCI)**

1030 Innes Road, Ottawa ON K1A 0M5, Canada  
Phone 613-998-3721 • [www.cci-icc.gc.ca](http://www.cci-icc.gc.ca)

See especially the links to *Preserving My Heritage*, with individual guidelines for preserving a range of materials.

### **Conservation on Line (CoOL)**

[www.cool.conservation-us.org](http://www.cool.conservation-us.org)

CoOL is the website for conservation professionals, but the general public will find much of interest, including a full text library of conservation information on a wide spectrum of topics related to the conservation of library, archives and museum materials. There are links to the home page of a number of conservation organizations.

### **Guild of Book Workers (GBW)**

521 Fifth Ave, New York, NY 10175-0083  
[www.guildofbookworkers.org](http://www.guildofbookworkers.org)

See especially their on-line guide to study opportunities in bookbinding. Copies of their *Supplies Directory* may be ordered by mail.

### **Heritage Preservation (HP)**

1012 14th Street, NW Suite 1200, Washington, DC 20005  
Phone 202-233-0800 • [www.heritagepreservation.org](http://www.heritagepreservation.org)

See especially their information on disaster preparedness and emergency response.

The organization has published three publications with excellent information on collections care. Order forms are available on the website:

*Caring for Your Collections*. 1992.

*Caring for Your Historic House*. 1998.

*Caring for Your Family Treasures*. 2001.

**National Park Service (NPS)**

[www.nps.gov/history](http://www.nps.gov/history)

See especially their on-line *Conserve-O-Gram* series on museum management:

[www.nps.gov/history/museum/publications/conservoogram/conserv.html](http://www.nps.gov/history/museum/publications/conservoogram/conserv.html)

**Northeast Document Conservation Center (NEDCC)**

100 Brickstone Square, Andover, MA 01810-1494

Phone 978-470-1010 • [www.nedcc.org](http://www.nedcc.org)

Their *Preservation of Library & Archival Materials: A Manual* is available on their website along with links to a wide range of library and archival organizations and resources.

**ADDITIONAL RESOURCES:**

*Guidelines for Information About Preservation Products*, ANSI/NISO Z39.77-2001. Bethesda, MD: NISO Press, 2001.

Guidelines for the types of information that should be included in vendor advertisements, catalogs, and promotional materials for products used to store library and archival materials. Includes a useful glossary of terms. Available online at [www.niso.org](http://www.niso.org).

Banks, Paul N. and Pilette, Roberta, Editors. *Preservation: Issues and Planning*. Chicago and London: American Library Association, 2000.

A concise analysis of important preservation management issues facing libraries and archives.

Lull, William P. with Banks, Paul N. *Conservation Environment Guidelines for Libraries and Archives*. Ottawa: Canadian Council of Archives, 1995.

An indispensable guide for librarians involved in building construction and renovation. Available from the Canadian Council of Archives, 3444 Wellington St., Room 1009, Ottawa, Canada K1A 0N3.

Ogden, Sherelyn, Editor. *Preservation of Library & Archival Materials: A Manual*. 3rd ed. Andover, MA: Northeast Document Conservation Center, 1999.

Consists of 50 technical leaflets that "provide the basic, practical information needed to enable non-conservator staff of libraries and archives to plan and implement sound collections care programs." The manual and individual technical leaflets are available online at [www.nedcc.org](http://www.nedcc.org).

Shultz, Arthur W., General Editor. *Caring for Your Collections: Preserving and Protecting Your Art and Other Collectibles*. New York: Harry N. Abrams, 1992.

Advice for the private collector on preservation of valuable art and artifacts. Experts explain the cause of deterioration and set forth guidelines for proper care and conservation. Other essays cover environment, home security, appraisal, authentication, donating collections, and selecting a professional conservator.

## SECTION 1: ARCHIVAL STORAGE OF PAPER

American Institute for Conservation of Historic and Artistic Works. *Matting and Framing Works of Art on Paper* and *Caring for Your Documents and Art on Paper*. Washington, DC: AIC, 2001 and 2003.

Two brochures prepared by AIC, the professional association for conservators in the United States, cover general storage issues and describe the basics of proper matting and framing. Available online at [www.conservation-us.org](http://www.conservation-us.org).

*American National Standard for Permanence of Paper for Publications and Documents in Libraries and Archives*, ANSI/NISO Z39.48-1992 (Revised 2002).

Sets out basic criteria for paper that will last several hundred years under normal use and storage. Available online at [www.niso.org](http://www.niso.org).

Bachman, Konstanze, Editor. *Conservation Concerns: A Guide for Collectors and Curators*. Washington, DC: Smithsonian Institution Press, 1992.

This compilation has basic information on collections. Particularly useful is the chapter "Warning Signs: When Works on Paper Require Conservation."

Ritzenthaler, Mary Lynn. *Preserving Archives and Manuscripts*. Chicago: Society of American Archivists, 1993.

An overview of preservation issues, ranging from the causes of deterioration of archives and library materials to the means of preventing and retarding deterioration. Includes detailed information on how to process and store specific types of materials.

Wilson, William K. *Environmental Guidelines for the Storage of Paper Records*. NISO Technical Report (NISO-TR01-1995). Bethesda, MD: NISO Press, 1995.

Provides guidelines for levels of temperature, relative humidity, exposure to light, gaseous contaminants, and particulates in libraries and archives. Also provides background information and a glossary of terms. Available online at [www.niso.org](http://www.niso.org).

## SECTION 2: PHOTOGRAPHY

Adelstein, Peter Z., *IPI Media Storage Quick Reference*. Rochester: Image Permanence Institute, 2004.

This guide explains in a simple fashion the role of storage conditions such as: temperature, relative humidity, and air quality for photographs, films, audio and video tapes, CDs and DVDs. It provides an easy to read booklet and a two-sided wheel.

*Care, Handling and Storage of Photographs*. International Federation of Library Associations and Institutions Core Programme on Presentation and Conservation, 1992. Available from the IFLA Core Programme Library of Congress, National Preservation Office, Washington, D.C. 20540.

*Conservation of Photographs*. Kodak Publication No. F-40. Rochester, NY; Eastman Kodak Company, 1985.

A good general overview of photographic materials and preservation topics.

Hendricks, Klaus B. *CCI Notes 16/1-16/6, 1995-96*. Canadian Conservation Institute (1030 Innes Road, Ottawa, Ontario, K1A 0M5 Canada).

Six technical leaflets that provide excellent summaries of current conservation information on photographic topics.

*IPI Storage Guide for Acetate Film*. Rochester, NY: Image Permanence Institute, 1993.

An overview of environmental specifications for acetate film storage with a methodology for assessing the impact of specific conditions on the longevity of film.

Keefe, Laurence E. and Inch, Dennis. *The Life of a Photograph: Archival Processing, Matting, Framing, Storage*. Second edition. Boston: Focal Press, 1990.

An excellent source of information on conservation framing and matting of photographs.

Lavédrine, Bertrand. *A Guide to the Preventative Conservation of Photograph Collections*. Los Angeles: The Getty Conservation Institute, 2003.

A thorough publication on recent research in the conservation of photographs. Now available in English, intended as a practical handbook for conservators, curators, collection managers, and others interested in photographic preservation.

Reilly, James M. *Care and Identification of 19th Century Photographic Prints*. Kodak Publication No. G-2s. Rochester, NY: Eastman Kodak Company, 1986.

A thorough guide to the identification and preservation of nineteenth century photographic prints. Touches on storage conditions and enclosures, and contains a chart for identifying print processes.

Ritzenthaler, Mary Lynn et al. *Administration of Photographic Collections*. SAA Basic Manual Series. Chicago: Society of American Archivists, 1984.

The best available guide to preserving and managing photographic archives.

Wilhelm, Henry. *The Permanence and Care of Color Photographs: Traditional and Digital Color Prints, Color Negatives, Slides, and Motion Pictures*. Grinnell, Iowa: Preservation Publishing Company, 1993.

An encyclopedic compendium of preservation information on color photography. Much information is also applicable to black and white material. Henry Wilhelm has conducted a number of tests on light-fastness of digital prints. His results may be downloaded at [www.wilhelm-research.com](http://www.wilhelm-research.com).

### **SECTION 3: ARCHIVAL STORAGE OF TEXTILES**

Bachman, Konstanze, Editor. *Conservation Concerns: A Guide for Collectors and Curators*. Washington, DC: Smithsonian Institution Press, 1992.

A compilation of basic information on collections. Four chapters deal with the basics of textile storage and conservation. Particularly useful is "Warning Signs: When Textiles Need Conservation."

*CCI Notes*, Chapter 13: "Textiles and Fibers." Ottawa: Canadian Conservation Institute, 1992-96.

Fifteen technical leaflets cover a range of topics on textiles. Download in html or pdf formats at [www.cci-icc.gc.ca/crc/notes/index-eng.aspx](http://www.cci-icc.gc.ca/crc/notes/index-eng.aspx).

Finch, Karen and Putnam, Greta. *The Care & Preservation of Textiles*. Berkeley, CA: LACIS, 1991.

A discussion of preventive conservation plus general instructions on surface cleaning and washing, sewing techniques, and illustrated case studies. Emphasis is on historic textiles. Available from LACIS, 3163 Adeline Street, Berkeley, CA 94703 or at [www.lacis.com/catalog](http://www.lacis.com/catalog).

Mailand, Harold and Alig, Dorothy. *Preserving Textiles*. Indianapolis: Indianapolis Museum of Art, 1999.

A good introduction to the care of historic textiles and dress.

Orlovsky, Patsy and Myron. *Quilts in America*. New York: Abbeville Press, 1992.

Chapter 11 on "Care" provides detailed instructions on cleaning quilts which could apply to other types of textiles.

The Henry Ford Museum publishes "Care and Preservation of Antique Textiles and Costumes" at [www.thehenryford.org/research/caring/textiles.aspx](http://www.thehenryford.org/research/caring/textiles.aspx).

A column about preserving historic objects, buildings and sites, published by the Minnesota Historical Society, is available at [www.mnhs.org/about/publications/techtalk.html](http://www.mnhs.org/about/publications/techtalk.html).

The Textile Museum in Washington DC has several pamphlets on textile care online at [www.textilemuseum.org/care/care.htm](http://www.textilemuseum.org/care/care.htm).

#### **SECTION 4: INTRODUCTION TO BOOK REPAIR**

Greenfield, Jane. *Books: Their Care and Repair*. New York: Wilson, 1983.

Lavender, Kenneth and Stockton, Scott. *Book Repair: A How-To-Do-It Manual for School and Public Libraries*. 2nd ed. New York: Neal Schuman, 2001.

*Preservation of Library & Archival Materials: A Manual*. 3rd ed. Andover, MA: Northeast Document Conservation Center, 1999.

Young, Laura. *Bookbinding & Conservation by Hand*. Reprint edition. Newark, Delaware: Oak Knoll Press, 1995.

# Your Trusted Source for Archival Solutions

This booklet has provided information on collections care for paper, photography, textiles and books. There are many additional types of collections that can benefit from proper care and storage, as well. General guidelines for care include:

- › Use of appropriate storage materials
- › Maintaining a stable environment with limited light
- › Handling of objects with care

## *When planning archival storage for:*

### Natural History Collections

Choose materials that don't abrade or deteriorate, and housings that offer stability and physical protection. Designs that keep both object and label visible will reduce the need for handling. Use unbuffered materials for protein-based specimens and items with dyes. Use buffered materials for plant-based objects; they can also be used with proteins if there is unbuffered interleaving between object and storage container.



### Media

Use acid-free enclosures and boxes to protect from dust and abrasion in long-term storage. Specially-sized envelopes, sleeves, cases and boxes are designed to store records, movie film, x-ray film, microfiche, microfilm and audio tape, and to protect against damage from light, off-gasing, film deterioration and the environment.



### Artifacts

Protect objects from physical damage by cushioning storage containers with crumpled tissue, batting or foam. Objects should be boxed individually or, if grouped, separated so they won't come in contact with each other. Minimize handling by using clear boxes or by placing labels prominently on the outside of storage containers.



---

**PRESERVE. PROTECT. DISPLAY.**

Protecting your collections requires more than placing objects in acid-free containers. It means guarding your objects against the many agents of deterioration. It also involves proper techniques for handling, displaying, repairing and preserving your artifacts.

Our approach to archival storage and care addresses all these issues, and more, by providing you not only with a wide selection of archival products and exhibit cases, but the information you need to protect your collections with confidence.

---

Request your **FREE General Reference & Archival Catalogs**  
at **GAYLORD.COM** to see our full line of products

**Gaylord**  
Your Trusted Source®

**CALL:** 1-800-448-6160

**FAX:** 1-800-272-3412

**WEB:** GAYLORD.COM